



MANNI **SIPRE**  
STEEL CO-CREATION

# THEORETICAL WEIGHT HANDBOOK



# THEORETICAL WEIGHTS

The information and indications in this catalogue are purely for information and are provided without obligation and without any liability on our part. The Weights indicated are purely theoretical as they are calculated on the basis of the nominal product dimensions and the specific Weight of steel of 7.85 kg/dm<sup>3</sup>; the actual Weight may differ, depending on the tolerances allowed by current customs and practices.



## INDEX

<b>01 / page 5</b>	HEAVY PLATES
<b>02 / page 16</b>	METAL SHEETS FROM COILS
<b>03 / page 19</b>	UPN BEAMS
<b>04 / page 20</b>	INP, IPE, IPEA BEAMS
<b>05 / page 23</b>	HEA/B/M, HEAA BEAMS
<b>06 / page 27</b>	ROUND AND SQUARE PROFILES
<b>07 / page 29</b>	FLAT PROFILES
<b>08 / page 33</b>	ANGLE PROFILES
<b>09 / page 35</b>	"L" PROFILES
<b>10 / page 36</b>	"T" PROFILES
<b>11 / page 37</b>	"U" PROFILES
<b>12 / page 38</b>	HANDRAILS
<b>13 / page 42</b>	PIPES
<b>14 / page 56</b>	BURBACH RAILS

# CONSTRUCTION QUALITY SHEET METAL

## KEY

<b>BS</b>	BASE STEEL
<b>QS</b>	QUALITY STEEL
<b>FN</b>	NON-RIMMED STEEL (SEMI-KILLED)
<b>FF</b>	FULLY KILLED STEEL (fine grain)
<b>(S...)</b>	QUALITY DESIGNATION ACCORDING TO EN 10027-1

## ACCORDING TO EN10025 STANDARDS

- With certificate of chemical analysis and mechanical steelwork testing in accordance with EN 10204
- With dimensional shape and mass tolerances according to EN 10029

### BS – BASE STEEL

- S275JR
- S355JR

### QS – QUALITY STEEL

- S275J0
- S275J2
- S355J0
- S355J2
- S355K2

## HULL PLATE WITH TESTING

\* Rina \* Lloyd's register of shipping

\* American bureau of shipping \* Bureau veritas \* Det Norske Veritas (in the various grades covered)

**HARDENED AND TEMPERED SHEET STEEL** with high yield strength and wear resistance

Normalized **C45 SHEET STEEL**

**ROLLED SLABS, WITH THICKNESSES FROM 80 TO 400 MM**

**HEAVY PLATE FROM EXCESS SLABS**

**SHEET METAL AND SLABS FROM STOCK, CERTIFICATIONS AND SPECIAL TESTING**

- According to NTC 2018 (Italian Ministerial Decree of 17 January 2018) - Reg. EU No. 305/2011
- With FERROVIE dello STATO testing.
- With testing by various CERTIFYING BODIES.
- WITH ULTRASONIC TESTING (U.T.) in accordance with EN10160 or ASTM standards

# BOILERMAKING QUALITY SHEET METAL

**ACCORDING TO THE FOLLOWING STANDARDS: EN 10028**

- P265 GH
- P 355 NH
- P275 NH

**ACCORDING TO ASME/ASTM STANDARDS**

- SA 516 GR 415/60 e 485/70

All the metal sheets we sell can be supplied thermally cut (oxy-propane and plasma), sandblasted and coated.

**THEORETICAL SHEET WEIGHT**

# DIMENSION RANGE HEAVY PLATE

THICKNESS mm	WEIGHT kg/mq	DIMENSIONS IN MILLIMETRES - Weight IN kg - SPECIFIC Weight 7.85 kg/dm <sup>3</sup>						
		6000 x 2000	6000 x 2500	8000 x 2000	6000 x 2500	10000 x 2500	12000 x 2500	12000 x 3000
		12 mq	15 mq	16 mq	20 mq	25 mq	30 mq	36 mq
5	39.25	471	589	628	785	982	1178	1413
6	47.1	566	707	754	942	1178	1413	1696
7	54.95	660	825	880	1099	1374	1649	1978
8	62.8	754	942	1005	1256	1570	1884	2261
9	70.65	848	1060	1131	1413	1767	2120	2544
10	78.5	942	1178	1256	1570	1963	2355	2826
11	86.35	1037	1296	1382	1727	2159	2591	3109
12	94.2	1131	1413	1508	1884	2355	2825	3392
13	102.05	1225	1531	1633	2041	2552	3062	3674
14	109.9	1319	1649	1759	2198	2748	3297	3957
15	117.75	1413	1767	1884	2355	2944	3533	4239
16	125.6	1508	1884	2010	2512	3140	3768	4522
18	141.3	1696	2120	2261	2826	3533	4239	5087
20	157	1884	2355	2512	3140	3925	4710	5652
22	172.7	2073	2591	2764	3454	4318	5181	6218
25	196.25	2355	2944	3140	3925	4907	5888	7065
26	204.1	2450	3062	3266	4082	5103	6123	7348
28	219.8	2638	3297	3517	4396	5495	6594	7913
30	235.5	2826	3533	3768	4710	5888	7065	8478
35	274.75	3297	4122	4396	5495	6869	8243	9891
40	314	3768	4710	5024	6280	7850	9420	11304
45	353.25	4239	5299	5652	7065	8832	10598	12717
50	392.5	4710	5888	6280	7850	9813	11775	14130
55	431.75	5181	6477	6908	8635	10794	12953	15543
60	471	5652	7065	7536	9420	11775	14130	16956
65	510.25	6123	7654	8164	10205	12757	15308	18396
70	549.5	6594	8243	8792	10990	13738	16485	19782
75	598.75	7065	8832	9420	11775	14719	17663	21555
80	628	7536	9420	10048	12560	15700	18840	22608
85	667.25	8007	10009	10676	13345	16682	20018	24021
90	706.5	8478	10598	11304	14130	17663	21195	25434
95	745.75	8949	11187	11923	14915	18644	22373	26847
100	785	9420	11775	12560	15700	19625	23550	28260
110	863.5	10362	12953	13816	17270	21588	25905	/
120	942	11304	14130	15072	18840	23550	28260	/
125	981.25	11775	14719	15700	19625	24532	29438	/
130	1020.5	12246	15308	16328	20410	25513	30615	/
140	1099	13188	16485	17584	21980	27475	/	/
150	1177.5	14130	17663	18840	23550	/	/	/

QUALITY ACCORDING TO EN 10025:2004 WITH TESTING

# BULB PLATES WITH NAVAL TESTING

\* RINA \* LLOYDS' REGISTER OF SHIPPING

\* DET NORSKE VERITAS ETC. (IN THE VARIOUS GRADES COVERED)

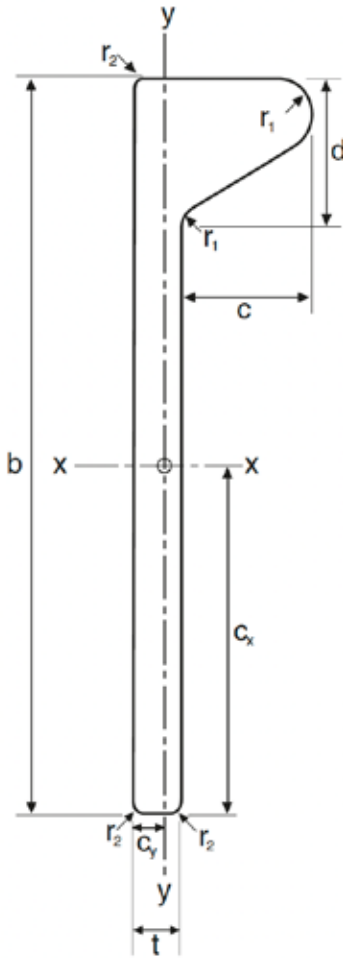

WIDTH mm	THICKNESS mm	WEIGHT kg/mm	WIDTH mm	THICKNESS mm	WEIGHT kg/mm
120	6	7.31	280	10.5	32.4
	7	8.25		11	33.5
	8	9.19		12	35.7
140	6.5 7 8 10	9.21	300	11	36.7
		9.74		12	39.0
		10.8		13	41.5
		13.0			
160	7 8 9 11.5	11.4	320	11.5	41.2
		12.7		12	42.5
		14.0		13	45.0
		17.3		14	47.5
180	8 9 10 11.5	14.8	340	12	46.1
		16.2		13	48.8
		17.6		14	51.5
		19.7		15	54.2
200	8.5 9 10 11 12	17.8	370	12.5	53.1
		18.5		13	54.6
		20.1		14	57.5
		21.7		15	60.5
		23.2		16	63.5
220	9 10 11 12	21.0	400	13	60.8
		22.8		14	63.9
		24.5		15	67.0
		26.2		16	70.2
240	9.5 10 11 12	24.4	430	14	70.6
		25.4		15	73.9
		27.4		17	80.6
		29.3		20	90.8
260	10 11 12	28.3			
		30.3			
		32.4			



# NON-ALLOY STEEL FOR BOILERS AND PRESSURE VESSELS

INDICATIVE CORRESPONDENCE BETWEEN THE  
MAIN EUROPEAN AND AMERICAN DESIGNATIONS

EURONORM EN 10028:2017	ASTM/ASME
P 235 G H	A 515 Gr. 55
P 265 G H	A 515 Gr. 60
P 275 N H	A 516 Gr. 60
P 275 N L 1	-
P 275 N L 2	-
P 295 G H	A 515 Gr. 65
P 355 G H	A 515 Gr. 70
P 355 N H	A 516 Gr. 70
P 355 N L 1	-
P 355 N L 2	-

FOR WALLS, ROOFS OR FALSE CEILINGS

# CORRUGATED SHEET METAL

## LG 20

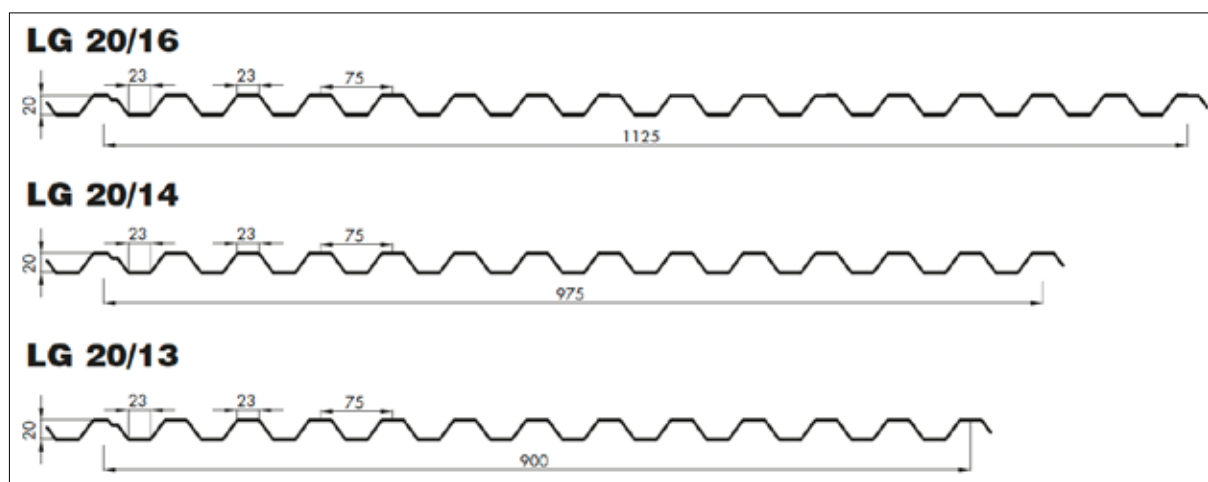

### SPECIFICATIONS

- Base materials: steel, aluminium.
- Length: as requested by the customer up to the maximum of 13,500 mm that can be transported.
- Usable pitch: 900 mm (LG 20/13), 975 mm (LG 20/14), 1125 mm (LG/16).
- Corrugation height: 20 mm.
- Corrugation pitch: 75 mm.

SECTION SPECIFICATIONS				
THICKNESS mm	0.5	0.6	0.7	0.8
Gross Weight (steel) kg/m <sup>2</sup>	4.89	5.87	6.85	7.83
Gross Weight (aluminium) kg/m <sup>2</sup>	1.69	2.03	2.37	2.71
J cm <sup>4</sup> /m	3.74	4.57	5.41	6.24
W cm <sup>3</sup> /m	3.66	4.45	5.23	6.00

### LOAD CAPACITIES

These depend on the base material type, thickness and type of installation (single or multiple span). The load capacities refer to sheets mounted horizontally and subject to the action of an evenly distributed incidental load. The designer is responsible for verifying the anchoring systems in relation to the number and layout.

MAXIMUM EVENLY DISTRIBUTED LOAD IN kg/m <sup>2</sup>													
THICKNESS mm	STEEL - Pitch m							ALUMINIUM - Pitch m					
	1.00	1.25	1.50	1.75	2.00	2.25	2.50	1.00	1.25	1.50	1.75	2.00	2.25
0.5	430	220	128	80	54	38	28	138	70	41	26	17	12
0.6	530	270	155	100	65	45	34	168	86	50	31	21	15
0.7	630	320	185	115	78	55	40	200	102	58	37	25	17
0.8	700	370	215	135	90	62	45	230	118	68	43	29	20

# LAMIERA GRECATA

## LG 28

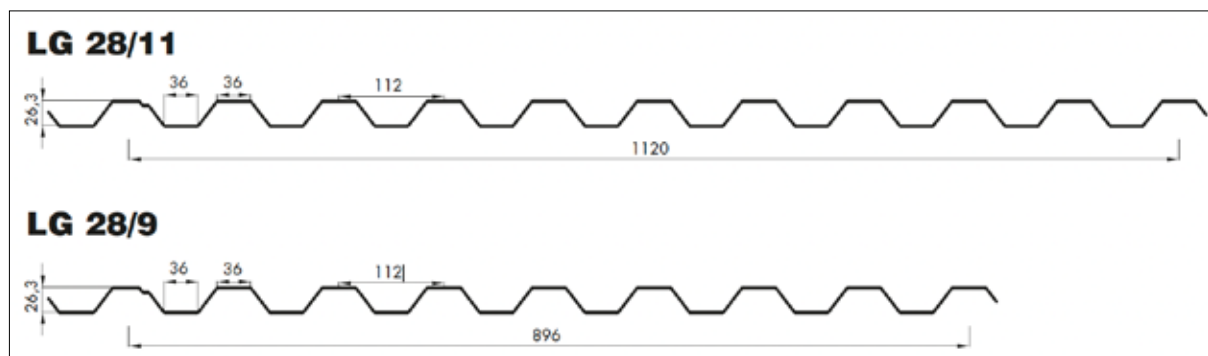

### SPECIFICATIONS

- Base materials: steel, aluminium.
- Length: as requested by the customer up to the maximum of 13,500 mm that can be transported.
- Usable pitch: 896 mm (LG 28/9), 1120 mm (LG 28/11).
- Corrugation height: 28 mm.
- Corrugation pitch: 112 mm.

SECTION SPECIFICATIONS				
THICKNESS mm	0.5	0.6	0.7	0.8
Gross Weight (steel) kg/m <sup>2</sup>	4.77	5.73	6.68	7.64
Gross Weight (aluminium) kg/m <sup>2</sup>	1.65	1.98	2.32	2.65
J cm <sup>4</sup> /m	5.96	7.29	8.62	9.94
W cm <sup>3</sup> /m	4.10	4.99	5.88	6.76

### LOAD CAPACITIES

These depend on the base material type, thickness and type of installation (single or multiple span). The load capacities refer to sheets mounted horizontally and subject to the action of an evenly distributed incidental load. The designer is responsible for verifying the anchoring systems in relation to the number and layout.

MAXIMUM EVENLY DISTRIBUTED LOAD IN kg/m <sup>2</sup>													
THICKNESS mm	STEEL - Pitch m							ALUMINIUM - Pitch m					
	1.00	1.25	1.50	1.75	2.00	2.25	2.50	1.00	1.25	1.50	1.75	2.00	2.25
0.5	690	350	205	128	85	60	44	220	112	65	41	28	19
0.6	820	430	250	155	105	74	53	268	138	80	50	34	24
0.7	1000	510	290	185	125	88	63	315	160	94	60	40	28
0.8	1110	580	340	215	145	100	75	365	185	108	68	46	32



FOR WALLS, ROOFS OR FALSE CEILINGS

# CORRUGATED SHEET METAL

## LG 38

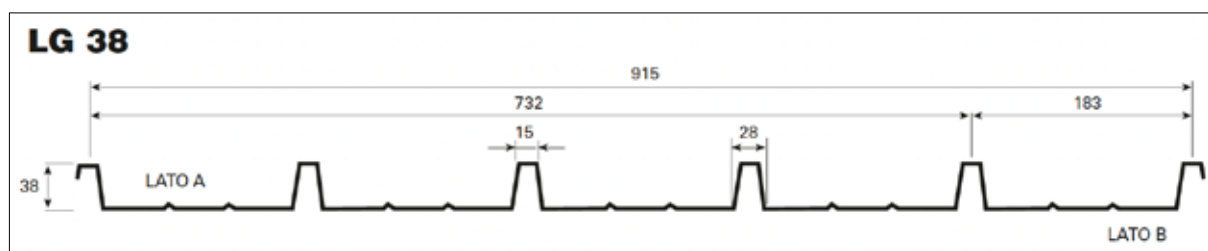

### SPECIFICATIONS

- Base materials: steel, aluminium, copper.
- Length: as requested by the customer up to the maximum of 12,400 mm that can be transported.
- Usable pitch: 732 mm (LG 38/732), 915 mm (LG 38/915).
- Corrugation height: 38 mm.
- Corrugation pitch: 183 mm.

### SECTION SPECIFICATIONS

THICKNESS mm	0.5	0.6	0.7	0.8	1.0
Weight kg/m <sup>2</sup> lordo	5.28	6.42	7.49	8.57	10.72
J cm <sup>4</sup> /m	10.3	13.7	16.0	18.3	22.8
W cm <sup>3</sup> /m	3.53	4.71	5.51	6.32	7.94

### LOAD CAPACITIES

These depend on the base material type, thickness and type of installation (single or multiple span). The load capacities refer to sheets mounted horizontally and subject to the action of an evenly distributed incidental load. The designer is responsible for verifying the anchoring systems in relation to the number and layout.

### MAXIMUM EVENLY DISTRIBUTED LOAD IN kg/m<sup>2</sup>

THICKNESS mm	Pitch m										
	1.00	1.25	1.50	1.75	2.00	2.25	2.50	2.75	3.00	3.25	3.5
0.5	305	200	140	100	75	55	45	40			
0.6	520	330	230	170	125	90 100	65 80	60	50		
0.7	610	390	270	195	150	105 115	75 90	55 75	60		
0.8	700	445	305	225	170	120 130	85 105	60 85	70		
1.0	880	560	385	280	210	150 165	110 130	80 110	60 90	75	
0.5	390	250	180	150	100	75	60	50	40		
0.6	650	415	285	210	160	125	100	80	60 65		
0.7	765	490	335	245	185	145	115	95	70 80	55 65	
0.8	875	560	385	280	215	165	135	110	89 90	65 75	50 65
1.0	1100	700	485	350	270	210	170	135	100 110	80 95	60 80

The values in red do not include deflection limitations.

FOR WALLS, ROOFS OR FALSE CEILINGS

# CORRUGATED SHEET METAL LG 40

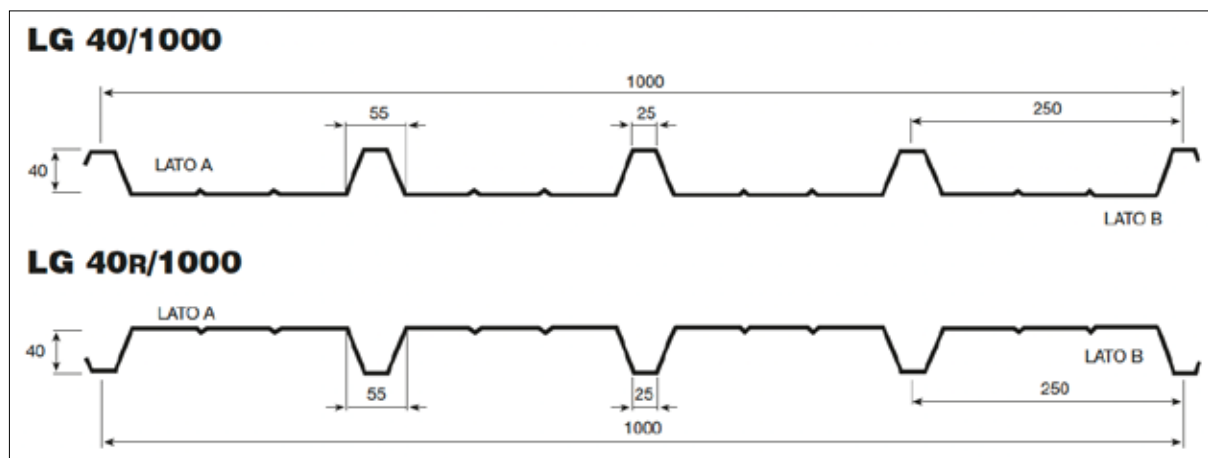

## SPECIFICATIONS

- Base materials: steel, aluminium, copper, stainless steel.
- Length: as requested by the customer up to the maximum of 13,500 mm that can be transported.
- Usable pitch: 896 mm (LG 28/9), 1120 mm (LG 28/11).
- Corrugation height: 28 mm.
- Corrugation pitch: 112 mm.

SECTION SPECIFICATIONS					
THICKNESS mm	0.5	0.6	0.7	0.8	1.0
Weight kg/m <sup>2</sup>	4.9	5.89	6.87	7.85	9.81
J cm <sup>4</sup> /m	12.3	16.05	18.72	21.40	26.75
W cm <sup>3</sup> /m	3.92	5.30	6.18	7.07	8.83

## LOAD CAPACITIES

These depend on the metal support type, thickness and type of installation (single or multiple span).

The load capacities refer to sheets mounted horizontally and subject to the action of an evenly distributed incidental load. The designer is responsible for verifying the anchoring systems in relation to the number and layout.

LG 40/1000 - MAXIMUM EVENLY DISTRIBUTED LOAD IN kg/m <sup>2</sup>													
THICKNESS mm	Pitch m												
	1.00	1.25	1.50	1.75	2.00	2.25	2.50	2.75	3.00	3.25	3.50	3.75	4
0.5	439	281	185	143	109	86	63 70	47 58	36 48				
0.6	614	393	273	200	153	115 121	84 98	63 81	48 68				
0.7	716	458	318	234	179	135 141	98 114	73 94	57 79	67 44	35 58		
0.8	820	524	364	267	205	154 162	112 131	84 108	65 91	51 77	41 67	33 58	
1.0	1024	655	455	334	256	193 202	140 163	105 135	81 113	64 97	51 83	41 72	34 64

0.5	570	365	252	180	141	111	90	67 73	51 62	40 53			
0.6	768	491	341	251	192	152	123	101	81 85	64 72	51 62		
0.7	896	573	398	292	224	177	143	118	95 99	74 84	59 73	48 63	
0.8	1025	656	455	334	256	202	164	135	108 113	85 97	68 83	55 72	45 64
1.0	1280	819	569	418	320	253	204	169	135 142	106 121	85 104	69 91	57 80

LG 40 <sub>R</sub> /1000 - MAXIMUM EVENLY DISTRIBUTED LOAD IN kg/m <sup>2</sup>													
THICKNESS mm	Pitch m												
	1.00	1.25	1.50	1.75	2.00	2.25	2.50	2.75	3.00	3.25	3.50	3.75	4
0.5	360	230	152	104 117	84 109	59 74	37 57	27 47					
0.6	504	322	224	145 164	97 126	68 99	49 80	37 66					
0.7	603	386	268	178 196	119 150	84 119	61 96	46 79	35 66				
0.8	701	449	311	241 229	143 175	100 138	73 112	55 92	42 78	33 65	27 56		
1.0	903	578	401	289 295	194 225	136 179	99 144	74 119	57 100	45 85	36 73	29 64	24 56

0.5	467	300	207	147	115	83 91	61 73	41 60	30 51				
0.6	630	403	280	205	157	113 124	83 100	62 83	48 70				
0.7	754	482	335	246	188	140 148	102 120	76 99	59 83	46 71	37 61		
0.8	877	561	389	286	219	168 173	122 140	92 116	71 97	55 83	44 71	36 62	
1.0	1129	722	502	368	282	223	165 180	124 149	95 125	75 106	60 92	49 80	40 70

The values in red do not include deflection limitations.

FOR LOAD-BEARING FLOORS OR DISPOSABLE FORMWORK

# CORRUGATED SHEET METAL LG 55

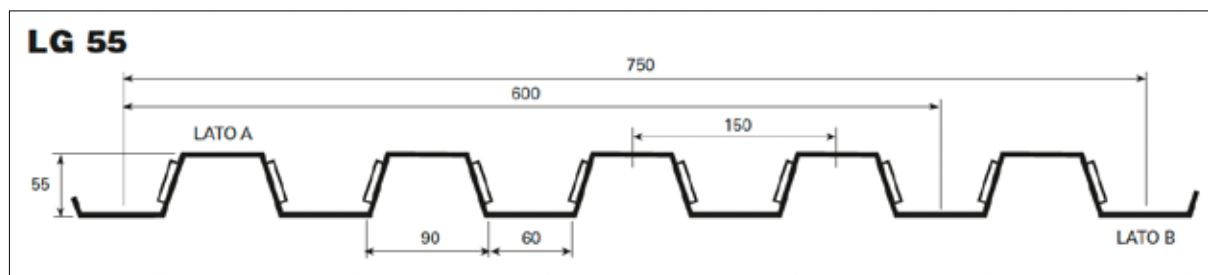

## SPECIFICATIONS

- Base materials: steel.
- Length: as requested by the customer up to the maximum that can be transported.
- Usable pitch: 600 mm (LG 55/600), 750 mm (LG 55/750)
- Corrugation height: 55 mm
- Corrugation pitch: 150 mm

SECTION SPECIFICATIONS					
THICKNESS mm	0.6	0.7	0.8	1.0	1.25
Weight kg/m <sup>2</sup>	7.8	9.1	10.5	13.1	16.3
J cm <sup>4</sup> /m	38.8	47.2	55.8	73.7	96.3
W cm <sup>3</sup> /m	11.3	13.9	16.8	23	31.3

## LOAD CAPACITIES

These depend on the metal support type, thickness and type of installation (single or multiple span).

The load capacities refer to sheets mounted horizontally and subject to the action of an evenly distributed load (e.g. concrete casting). The designer is responsible for choosing and sizing the reinforcements, any plugs and the concrete slab in relation to the type and performance required.

**MAXIMUM EVENLY DISTRIBUTED LOAD IN kg/m<sup>2</sup>**

THICKNESS mm	Pitch m																
	1.00	1.25	1.50	1.75	2.00	2.25	2.50	2.75	3.00	3.25	3.50	3.75	4	4.25	4.5	4.75	5
06	1433	914	633	463	352	266 277	192 223	183 142	108 152	83 128	65 110	51 94	41 82	33 72	26 63	21 56	17 50
0.7	1776	1133	784	573	436	324 343	233 276	173 226	131 188	101 159	79 136	62 117	49 102	40 89	32 78	25 69	20 61
0.8	2142	1367	946	693	528	385 415	278 334	206 275	157 229	121 194	95 166	75 143	60 124	49 109	39 96	32 85	26 76
1.0	2929	1871	1295	948	730	509 569	368 459	273 377	208 315	161 266	126 228	101 197	81 172	65 151	53 133	43 116	36 106
1.25	3990	2548	1765	1293	955 986	666 776	482 626	358 515	272 430	211 364	166 312	132 270	106 235	86 207	70 183	57 163	47 145

06	1794	1145	793	580	442	348	280	230	185 192	144 163	114 139	91 120	73 105	60 92	49 81	41 72	34 64
0.7	2224	1420	984	721	550	433	349	287	227 240	177 203	140 174	112 151	91 132	75 116	62 102	51 91	43 81
0.8	2680	1711	1185	868	662	521	420	346 351	268 289	208 245	165 210	132 181	107 158	88 139	72 123	60 109	50 98
1.0	3685	2341	1622	1189	907	714	576	464 474	354 397	276 336	219 288	176 249	143 218	117 192	97 170	80 151	67 135
1.25	4991	3189	2210	1620	1237	974	786	697 647	464 541	362 459	287 394	230 341	187 298	153 262	127 232	106 207	88 185

The values in red do not include deflection limitations.

FOR WATERPROOF CLADDING IN RESIDENTIAL CONSTRUCTION

# NON-SELF-SUPPORTING CORRUGATED SHEET, PROFILED AND SHAPED AS TILES, LG 50

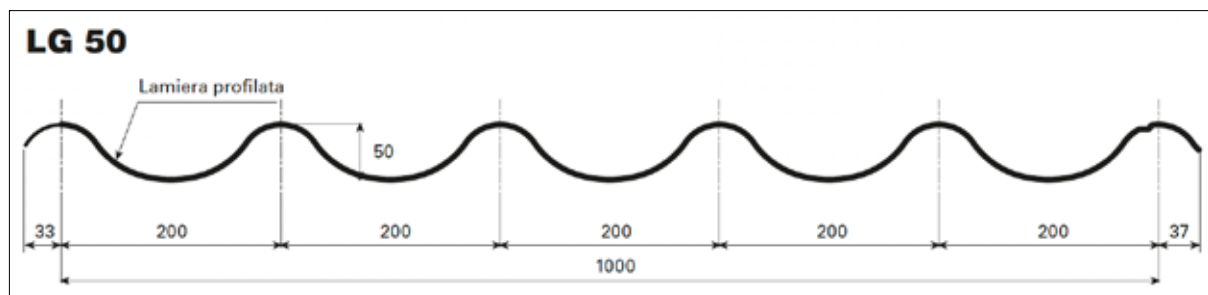

## SPECIFICATIONS

- Base materials: steel, aluminium, copper, stainless steel.
- Lengths: 1200 - 2250 - 2950 - 4000 - 4700 - 5050 - 5750 - 6100 - 6450 mm.
- Usable pitch: 1000 mm.
- Tile height: 50 mm.
- Transversal tile pitch: 200 mm.
- Longitudinal tile pitch: 350 mm.

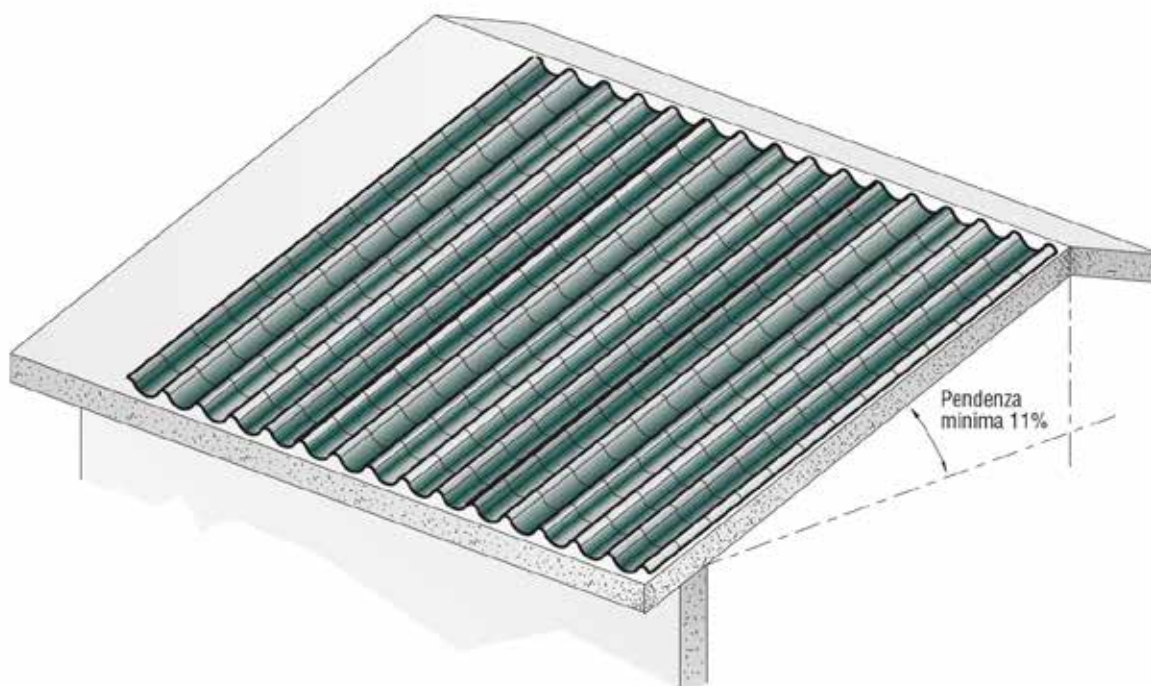

# SHEET METAL FROM COILS

THICKNESS mm	WEIGHT kg/mq	DIMENSIONS IN MILLIMETRES							
		1000 x 2000	1250 x 2500	1500 x 3000	1500 x 6000	1750 x 6000	1800 x 6000	2000 x 6000	2000 x 8000
		2 mq	3.1 mq	4.5 mq	9 mq	10.5 mq	10.8 mq	12 mq	16 mq
WEIGHT IN kg									
1	7.85	15.7	24.5	35					
1.2	9.42	18.8	29.5	42					
1.5	11.8	23.6	36.7	53					
1.8	14.1	28.2	44.2	64					
2	15.7	31.4	49	71					
2.5	19.6	39.3	61	88					
3	23.6	47.1	73	106	212.4	247.3	255	282.6	376.8
3.5	27.5	55	86	124					
4	31.4	62.8	98	141	282.6	329.7	339	377	502.4
5	39.3	78.5	123	176	352	412	424	472	628
6	47.1	94.2	147	212	424	494	509	565	753
7	55	110	172	247	494	576	594	660	879
8	62.8	126	196	282	564	659	678	754	1004
9	70.6	141	221	318	636	741	762	847	1130
10	78.5	157	245	353	706	824	848	942	1256
12	94.2	188.4	294	424	847.8		1017.2	1132	
15	117.8	236	368	530	1060		1272	1416	
20	157	314	490	706	1412		1696	1884	

EURONORM 10025 - UNI 7070 / EU 25-70

# STEEL CHECKER PLATES

HOT ROLLED

THICKNESS (1) mm	WEIGHT kg/mq	DIMENSIONS IN MILLIMETRES				
		1000 x 2000	1000 x 3000	1250 x 2500	1500 x 3000	1500 x 6000
		WEIGHT IN kg				
2	18.2	36.4				
2.5	22.2	45		69	100	
3	28.6	57.2	85.8	89.4	128.7	257.4
4	36.5	73.0	109.5	114.0	164.3	328.5
5	44.3	88.6	132.9	138.5	199.4	398.7
6	52.1	104.2	156.3	163.0	234.5	468.9
7	60	120.0	180.0	187.5	270.0	540.0
8	67.8	135.6	203.4	211.9	305.1	610.2
10	83.6	167.2	250.8	261.2	376.2	752.4
12	99.1	198.2	297.3	309.7	446.0	891.9
14	115.0					

**(1) Thickness does not include the chequering**

EURONORM 10025 - UNI 7070 / EU 25

# EMBOSSED SHEET METAL

THICKNESS mm	WEIGHT kg/mq	DIMENSIONS IN MILLIMETRES		
		2000 x 1000	2500 x 1250	3000 x 1500
		Weight in kg		
2.0	17.36	34.72	54.25	72.12
2.5	21.75	43.50	68.0	97.9
3	26.05	52.1	81.1	117.0
4	33.95	67.9	106.0	153.0
5	41.75	83.5	130.1	187.6
6	49.6	99.2	154	223
8	65.3	130.6	204	284
10	81.1	162.2	250	365



# GALVANIZED SHEET METAL

THICKNESS mm	WEIGHT kg/mq	DIMENSIONS IN MILLIMETRES		
		1000 X 2000	1250 X 2500	1500 X 3000
		Weight in kg		
0.3	2.36	4.72		
0.35	2.75	5.51		
0.4	3.14	6.28		
0.45	3.53	7.06		
0.5	3.93	7.86		
0.6	4.71	9.42	14.7	21.19
0.8	6.28	12.6	19.7	28.3
1	7.85	15.7	24.5	35
1.2	9.42	18.8	29.5	42
1.5	11.8	23.6	36.7	53
1.8	14.1	28.2	44.2	64
2	15.7	31.4	49	71
2.5	19.6	39.3	61	88
3	23.6	47.1	73	106
3.5	27.5	55	85.9	123.6
4	31.4	62.8	98	141
5	39.2	78.5	123	176

# "U" BEAMS AND IRONS

## "UNP" PROFILES

EN 10365 / 10024

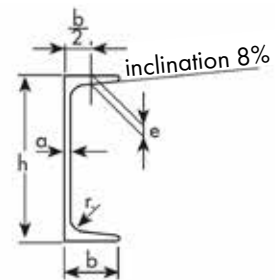

Desi- gnat.	Weight kg/m	Sur. m <sup>2</sup> /t	Sect. cmq	DIMENSIONS					Specifications with reference to the neutral axis					
				h mm	b mm	a mm	e mm	r mm	x-x			y-y		
									J <sub>x</sub> cm <sup>4</sup>	W <sub>x</sub> cm <sup>3</sup>	i <sub>x</sub> cm	J <sub>y</sub> cm <sup>4</sup>	W <sub>y</sub> cm <sup>3</sup>	i <sub>y</sub> cm
30	4.27	/	5.44	30	33	5	/	/	36.39	4.26	1.08	5.1	2.60	0.968
40	4.88	/	6.21	40	35	5	/	/	14.1	7.07	1.51	6.68	3.08	1.04
50	5.59	/	7.12	50	38	5	/	/	26.5	10.6	1.93	9.1	3.74	1.13
65	7.09	/	9.03	65	42	5.5	/	/	57.5	17.7	2.52	14.0	5.05	1.25
80	8.65	36.1	11.0	80	45	6	7.76	8	106	26.5	3.10	19.4	6.35	1.33
100	10.6	35.10	13.5	100	50	6	8.26	8.5	205	41.1	3.91	29.1	8.45	1.47
120	13.3	32.39	17.0	120	55	7	8.72	9	364	60.7	4.63	43.1	11.1	1.59
140	16	30.56	20.4	140	60	7	9.72	10	605	86.4	5.45	61.5	14.7	1.75
160	18.9	29.04	24.0	160	65	7.5	10.2	10.5	925	116	6.21	85.0	18.2	1.88
180	22.0	27.77	28	180	70	8	10.68	11	1354	150	6.96	113	22.4	2.01
200	25.3	26.13	32.2	200	75	8.5	11.16	11.5	1911	191	7.71	148	26.9	2.14
220	29.4	24.42	37.4	220	80	9	12.14	12.5	2691	245	8.48	196	33.5	2.29
240	33.2	23.34	42.3	240	85	9.5	12.62	13	3599	300	9.22	247	39.5	2.41
260	37.9	22.00	48.3	260	90	10	13.6	14	4824	371	10.0	317	47.8	2.56
280	41.9	21.29	53.4	280	95	10	14.6	15	6276	448	10.8	398	57.1	2.73
300	46.1	20.56	58.8	300	100	10	15.6	16	8.028	535	11.7	493	67.5	2.90
320	59.5	16.50	75.8	320	100	14	17.5	17.5	10870	679	12.10	597	80.6	2.81
350	60.6	17.28	77.3	350	100	14	16	16	12840	734	12.90	570	75	2.72
380	63.1	17.59	80.4	380	102	13.5	16	16	15760	829	14.00	615	78.7	2.77
400	16.46	16.46	91.5	400	110	14	18	18	20350	1020	14.90	846	102	3.04

# "IPN" PROFILES

EN 10365 / 10024

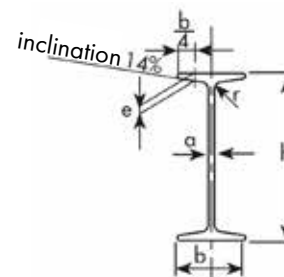

Desi- gnat.	Weight kg/m	Sur. m <sup>2</sup> /t	Sect. cmq	DIMENSIONS					Specifications with reference to the neutral axis					
				h mm	b mm	a mm	e mm	r mm	x-x			y-y		
									J <sub>x</sub> cm <sup>4</sup>	W <sub>x</sub> cm <sup>3</sup>	i <sub>x</sub> cm	J <sub>y</sub> cm <sup>4</sup>	W <sub>y</sub> cm <sup>3</sup>	i <sub>y</sub> cm
80	5.95	51.18	7.58	80	42	3.9	5.76	3.9	77.8	19.5	3.20	6.29	3.00	0.91
100	8.32	44.36	10.6	100	50	4.5	6.64	4.5	171	34.2	4.01	12.2	4.88	1.07
120	11.20	39.55	14.2	120	58	5.1	7.52	5.1	328	54.7	4.81	21.5	7.41	1.23
140	14.40	35.10	18.3	140	66	5.7	8.40	5.7	573	81.9	5.61	35.2	10.7	1.40
160	17.90	32.12	22.8	160	74	6.3	9.28	6.3	935	117	6.40	54.7	14.8	1.55
180	21.9	29.22	27.9	180	82	6.9	10.16	6.9	1446	161	7.20	81.3	19.8	1.71
200	26.3	27.06	33.5	200	90	7.5	11.04	7.5	2142	214	8.00	117	26.0	1.87
220	31.1	24.92	39.6	220	98	8.1	11.92	8.1	3060	278	8.80	162	33.1	2.02
240	36.2	23.31	46.1	240	106	8.7	12.80	8.7	4246	354	9.59	221	41.7	2.20
260	41.9	21.62	53.4	260	113	9.4	13.77	9.4	5744	442	10.4	288	51.0	2.32
280	48.0	20.17	61.1	280	119	10.1	14.85	10.1	7587	542	11.1	364	61.2	2.45
320	61.1	17.87	77.8	320	131	11.5	16.90	11.5	12510	782	12.7	555	84.7	2.67
340	68.1	16.91	86.8	340	137	12.2	17.87	12.2	15700	923	13.5	674	98.4	2.80
360	76.2	15.90	97.1	360	143	13	19.05	13	19610	1089	14.2	818	114	2.90
380	84.0	15.12	107	380	149	13.7	20.02	13.7	24010	1264	15.0	975	131	3.02
400	92.6	14.39	118	400	155	14.4	21.10	14.4	29210	1461	15.7	1158	149	3.13
450	115	12.87	147	450	170	16.2	24.3	16.2	45850	2040	17.7	1730	203	3.43
500	141	11.56	179	500	185	18	27	18	68740	2750	19.6	2480	268	3.72
550	166	10.84	212	550	200	19	30	19	99180	3610	21.6	3490	349	4.02

# "IPE" BEAMS

EN 10365 / EN 10034

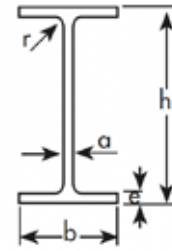

Desi- gnat.	Weight kg/m	Sur. m <sup>2</sup> /t	Sect. cm <sup>2</sup>	DIMENSIONS					Specifications with reference to the neutral axis					
				h mm	b mm	a mm	e mm	r mm	x-x			y-y		
									J <sub>x</sub> cm <sup>4</sup>	W <sub>x</sub> cm <sup>3</sup>	i <sub>x</sub> cm	J <sub>y</sub> cm <sup>4</sup>	W <sub>y</sub> cm <sup>3</sup>	i <sub>y</sub> cm
80	6.00	54.67	7.64	80	46	3.8	5.2	5.5	80.1	20.0	3.24	8.49	3.69	1.05
100	8.10	49.38	10.3	100	55	4.1	5.7	7	171	34.2	4.07	15.9	5.79	1.24
120	10.4	45.67	13.2	120	64	4.4	6.3	7	318	53.0	4.90	27.7	8.65	1.45
140	12.9	42.71	16.4	140	73	4.7	6.9	7	541	77.3	5.74	44.9	12.3	1.65
160	15.8	39.43	20.1	160	82	5.0	7.4	9	869	109	6.58	68.3	16.7	1.84
180	18.8	37.13	23.9	180	91	5.3	8.0	9	1320	146	7.42	101	22.2	2.05
200	22.4	34.29	28.5	200	100	5.6	8.5	12	1940	194	8.26	142	28.5	2.24
220	26.2	32.37	33.4	220	110	5.9	9.2	12	2770	252	9.11	205	37.3	2.48
240	30.7	30.03	39.1	240	120	6.2	9.8	15	3890	324	9.97	284	47.3	2.69
270	36.1	28.81	45.9	270	135	6.6	10.2	15	5790	429	11.2	420	62.2	3.02
300	42.2	27.49	53.8	300	150	7.1	10.7	15	8360	557	12.5	604	80.5	3.35
330	49.1	25.46	62.6	330	160	7.5	11.5	18	11770	713	13.7	788	98.5	3.55
360	57.1	23.64	72.7	360	170	8.0	12.7	18	16270	904	15.0	1040	123	3.79
400	66.3	22.17	84.5	400	180	8.6	13.5	21	23130	1160	16.5	1320	14.6	3.95
450	77.6	20.75	98.8	450	190	9.4	14.6	21	33740	1500	18.5	1680	176	4.12
500	90.7	19.18	116	500	200	10.2	16.0	21	48200	1930	20.4	2140	214	4.31
550	106	17.74	134	550	210	11.1	17.2	24	67120	2440	22.3	2670	254	4.45
600	122	16.48	156	600	220	12.0	19.0	24	92080	3070	24.3	3390	308	4.66

# "IPEA" LIGHTWEIGHT ROLLED BEAMS

EN 10365 / EN 10034

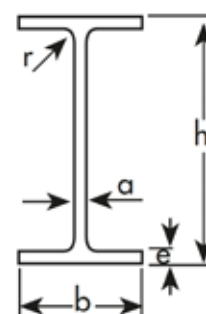

Designat.	Weight kg/m	Sur. m <sup>2</sup> /t	Sect. cm <sup>2</sup>	DIMENSIONS					Specifications with reference to the neutral axis					
				h mm	b mm	a mm	e mm	r mm	x-x			y-y		
									J <sub>x</sub> cm <sup>4</sup>	W <sub>x</sub> cm <sup>3</sup>	i <sub>x</sub> cm	J <sub>y</sub> cm <sup>4</sup>	W <sub>y</sub> cm <sup>3</sup>	i <sub>y</sub> cm
80	5		6.4	78	46	3.3	4.2	5	63.4	16.5	3.17	6.8	2.9	1
100	6.9		8.8	98	55	3.6	4.7	7	141.2	28.8	4	13.1	4.7	1.2
120	8.6	54.50	11	118	64	3.8	5.1	7	257	43.8	4.83	22.4	7	1.42
140	10.5	52.10	13.4	138	73	3.8	5.6	7	435	63.3	5.70	36.4	9.98	1.65
160	12.7	48.74	16.2	157	82	4	5.9	9	689	87.8	6.53	54.4	13.3	1.83
180	15.4	45.06	19.6	177	91	4.3	6.5	9	1063	120	7.37	81.9	18	2.05
200	18.4	41.52	23.5	197	100	4.5	7	12	1591	162	8.23	117	23.4	2.23
220	22.2	37.97	28.3	217	110	5	7.7	12	2317	214	9.05	171	31.2	2.46
240	26.2	35.04	33.3	237	120	5.2	8.3	15	3290	278	9.94	240	40	2.68
270	30.7	33.88	39.1	267	135	5.5	8.7	15	4917	368	11.2	358	53	3.02
300	36.5	31.78	46.5	297	150	6.1	9.2	15	7173	483	12.4	519	69.2	3.34
330	43	29.07	54.7	327	160	6.5	10	8	10230	626	13.7	685	85.6	3.54
360	50.2	26.89	64	357	170	6.6	11.5	18	14520	812	15.1	944	111	3.84
400	57.4	25.44	73.1	397	180	7	12	21	20290	1020	16.7	1170	130	4
450	67.2	23.81	85.6	447	190	7.6	13.1	21	29760	1330	18.6	1502	150	4.19
500	79.4	21.91	101	497	200	8.4	14.5	21	42930	1730	20.6	1939	194	4.38
550	92.1	20.30	117	547	210	9	15.7	24	59980	2190	22.6	2432	232	4.55
600	108	18.61	137	597	220	9.8	17.5	24	82920	2780	24.6	3116	283	4.77

# "HEA" PARALLEL BROAD FLANGE BEAMS

## lightweight series

EN 10365 / EN 10034

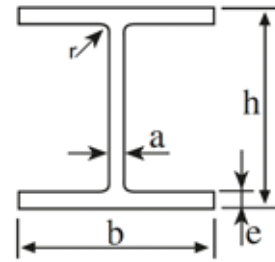

Designat.	Weight kg/m	Sur. m <sup>2</sup> /t	Sect. cm <sup>2</sup>	DIMENSIONS					Specifications with reference to the neutral axis					
				h mm	b mm	a mm	e mm	r mm	x-x			y-y		
									J <sub>x</sub> cm <sup>4</sup>	W <sub>x</sub> cm <sup>3</sup>	i <sub>x</sub> cm	J <sub>y</sub> cm <sup>4</sup>	W <sub>y</sub> cm <sup>3</sup>	i <sub>y</sub> cm
100	16.7	33.59	21.2	96	100	5	8	12	349	72.8	4.06	134	26.8	2.51
120	19.9	34.02	25.3	114	120	5	8	12	606	106	4.89	231	38.5	3.02
140	24.7	32.15	31.4	133	140	5.5	8.5	12	1030	155	5.73	389	55.6	3.52
160	30.4	29.80	38.8	152	160	6	9	15	1670	220	6.57	616	76.9	3.98
180	35.5	28.73	45.3	171	180	6	9.5	15	2510	294	7.45	925	103	4.52
200	42.3	26.95	53.8	190	200	6.5	10	18	3690	389	8.28	1340	134	4.98
220	50.5	24.95	64.3	210	220	7	11	18	5410	515	9.17	1950	178	5.51
240	60.3	22.72	76.8	230	240	7.5	12	21	7760	675	10.1	2770	231	6.00
260	68.2	21.70	86.8	250	260	7.5	12.5	24	10450	836	11.0	3670	282	6.50
280	76.4	20.94	97.3	270	280	8	13	24	13670	1010	11.9	4760	340	7.00
300	88.3	19.48	113	290	300	8.5	14	27	18260	1260	12.7	6310	421	7.49
320	97.6	18.03	124	310	300	9	15.5	27	22930	1480	13.6	6990	466	7.49
340	105	17.05	133	330	300	9.5	16.5	27	27690	1680	14.4	7440	496	7.46
360	112	16.34	143	350	300	10	17.5	27	33090	1890	15.2	7890	526	7.43
400	125	15.28	159	390	300	11	19	27	45070	2310	16.8	8560	571	7.34
450	140	14.36	178	440	300	11.5	21	27	63720	2900	18.9	9470	631	7.29
500	155	13.61	198	490	300	12	23	27	86970	3550	21.0	10370	691	7.24
550	166	13.31	212	540	300	12.5	24	27	111900	4150	23.0	10820	721	7.15
600	178	12.98	226	590	300	13	25	27	141200	4790	25.0	11270	751	7.05
650	190	12.68	242	640	300	13.5	26	27	175200	5470	26.9	11720	782	6.97
700	204	12.25	260	690	300	14.5	27	27	215300	6240	28.8	12180	812	6.84
800	224	12.05	286	790	300	15	28	30	303400	7680	32.6	12640	843	6.65
900	252	11.51	321	890	300	16	30	30	422100	9480	36.3	16550	903	6.50
1000	272	11.40	347	990	300	16.5	31	30	553800	11190	40.0	14000	934	6.35

# "HEB" PARALLEL BROAD FLANGE BEAMS

## normal series

EN 10365 / EN 10034

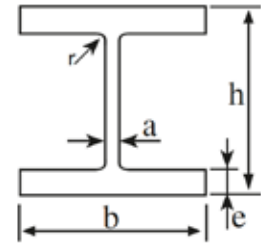

Desi- gnat.	Weight kg/m	Sur. m <sup>2</sup> /t	Sect. cm <sup>2</sup>	DIMENSIONS					Specifications with reference to the neutral axis					
				h mm	b mm	a mm	e mm	r mm	x-x			y-y		
									J <sub>x</sub> cm <sup>4</sup>	W <sub>x</sub> cm <sup>3</sup>	i <sub>x</sub> cm	J <sub>y</sub> cm <sup>4</sup>	W <sub>y</sub> cm <sup>3</sup>	i <sub>y</sub> cm
100	20.4	27.79	26.0	100	100	6	10	12	450	89.9	4.16	167	33.5	2.53
120	26.7	25.69	34.0	120	120	6.5	11	12	864	144	5.04	318	52.9	3.06
140	33.7	23.89	43.0	140	140	7	12	12	1510	216	5.93	550	78.5	3.58
160	42.6	21.55	54.3	160	160	8	13	15	2490	311	6.78	889	111	4.05
180	51.2	20.31	65.3	180	180	8.5	14	15	3830	426	7.66	1360	151	4.57
200	61.3	18.76	78.1	200	200	9	15	18	5700	570	8.54	2000	200	5.07
220	71.5	17.76	91.0	220	220	9.5	16	18	8090	736	9.43	2840	258	5.59
240	83.2	16.59	106	240	240	10	17	21	11260	938	10.3	3920	327	6.08
260	93.0	16.13	118	260	260	10	17.5	24	14920	1150	11.2	5130	395	6.58
280	103	15.73	131	280	280	10.5	18	24	19270	1380	12.1	6590	471	7.09
300	117	14.79	149	300	300	11	19	27	25170	1680	13.0	8560	571	7.58
320	127	13.94	161	320	300	11.5	20.5	27	30800	1930	13.8	9240	616	7.57
340	134	13.51	171	340	300	12	21.5	27	36660	2160	14.6	9690	646	7.53
360	142	13.03	181	360	300	12.5	22.5	27	43190	2400	15.5	10140	676	7.49
400	155	12.45	198	400	300	13.5	24	27	57680	2880	17.1	10820	721	7.40
450	171	11.87	218	450	300	14	26	27	79890	3550	19.1	11720	781	7.33
500	187	11.34	239	500	300	14.5	28	27	107200	4290	21.2	12620	842	7.27
550	199	11.16	254	550	300	15	29	27	136700	4970	23.2	13080	872	7.17
600	212	10.94	270	600	300	15.5	30	27	171000	5700	25.2	13500	902	7.08
650	225	10.76	286	650	300	16	31	27	210600	6480	27.1	13980	932	6.99
700	241	10.46	306	700	300	17	32	27	256900	7340	29.0	14440	963	6.87
800	262	10.34	334	800	300	17.5	33	30	359100	8980	32.8	14900	994	6.68
900	291	10.00	371	900	300	18.5	35	30	494100	10980	36.5	15820	1050	6.53
1000	314	9.90	400	1000	300	19	36	30	644700	12890	40.1	6280	1090	6.38

# "HEB" PARALLEL BROAD FLANGE BEAMS reinforced series

EN 10365 / EN 10034

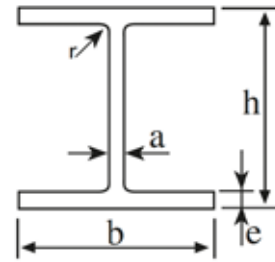

Desi- gnat.	Weight kg/m	Sur. m <sup>2</sup> /t	Sect. cm <sup>2</sup>	DIMENSIONS					Specifications with reference to the neutral axis					
				h mm	b mm	a mm	e mm	r mm	x-x			y-y		
									J <sub>x</sub> cm <sup>4</sup>	W <sub>x</sub> cm <sup>3</sup>	i <sub>x</sub> cm	J <sub>y</sub> cm <sup>4</sup>	W <sub>y</sub> cm <sup>3</sup>	i <sub>y</sub> cm
100	41.8	14.81	53.2	120	106	12	20	12	1140	190	4.63	399	75.3	2.74
120	52.1	14.17	66.4	140	126	12.5	21	12	2020	288	5.51	703	112	3.25
140	63.2	13.56	80.6	160	146	13	22	12	3290	411	6.39	1140	157	3.77
160	76.2	12.73	97.1	180	166	14	23	15	5100	566	7.25	1760	212	4.26
180	88.9	12.26	113	200	186	14.5	24	15	7480	748	8.13	2580	277	4.77
200	103	11.65	131	220	206	15	25	18	10640	967	9.00	3650	354	5.27
220	117	11.28	149	240	226	15.5	26	18	14600	1220	9.89	5010	444	5.79
240	157	9.23	200	270	248	18	32	21	24290	1800	11.0	8150	657	6.39
260	172	9.13	220	290	268	18	32.5	24	31310	2160	11.9	10450	780	6.90
280	189	8.94	240	310	288	18.5	33	24	39550	2550	12.8	13160	914	7.40
300	238	7.69	303	340	310	21	39	27	59200	3480	14.0	19400	1250	8.00
320	245	7.63	312	359	309	21	40	27	68130	3800	14.8	19710	1280	7.95
340	248	7.66	316	377	309	21	40	27	76370	4050	15.6	19710	1280	7.90
360	250	7.72	319	395	308	21	40	27	84870	4300	16.3	19520	1270	7.83
400	256	7.81	326	432	307	21	40	27	104100	4820	17.9	19340	1260	7.70
450	263	7.98	335	478	307	21	40	27	131500	5500	19.8	19340	1260	7.59
500	270	8.07	344	524	306	21	40	27	161900	6180	21.7	19150	1250	7.46
550	278	8.20	354	572	306	21	40	27	198000	6920	23.6	19160	1250	7.35
600	285	8.32	364	620	305	21	40	27	237400	7660	25.6	18980	1240	7.22
650	293	8.43	374	668	305	21	40	27	281700	8430	27.5	18980	1240	7.13
700	301	8.50	383	716	304	21	40	27	329300	9200	29.3	18860	1240	7.01
800	317	8.68	404	814	303	21	40	30	442600	10870	33.1	18630	1230	6.79
900	333	8.80	424	910	302	21	40	30	570400	12540	36.7	18450	1220	6.60
1000	349	8.97	444	1008	302	21	40	30	722300	14330	40.3	18460	1220	6.45



# "HEAA" LIGHTWEIGHT ROLLED BEAMS

EN 10365 / EN 10034

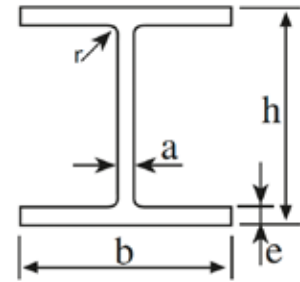

Desi- gnat.	Weight kg/m	Sur. m <sup>2</sup> /t	Sect. cmq	DIMENSIONS					Specifications with reference to the neutral axis					
				h mm	b mm	a mm	e mm	r mm	x-x			y-y		
									J <sub>x</sub> cm <sup>4</sup>	W <sub>x</sub> cm <sup>3</sup>	i <sub>x</sub> cm	J <sub>y</sub> cm <sup>4</sup>	W <sub>y</sub> cm <sup>3</sup>	i <sub>y</sub> cm
100	12.2	45.33	15.6	91	100	4.2	5.5	12	237	52	3.89	92	18.4	2.43
120	14.6	45.82	18.6	109	120	4.2	5.5	12	413	76	4.72	159	26.5	2.93
140	18.1	43.48	23	128	140	4.3	6	12	719	112	5.59	275	39.3	3.45
160	23.8	37.86	30.4	148	160	4.5	7	15	1283	173	6.50	479	60	3.97
180	28.7	35.54	36.5	167	180	5	7.5	15	1967	236	7.34	730	81.1	4.47
200	34.6	32.66	44.1	186	200	5.5	8	18	2944	317	8.17	1068	107	4.92
220	40.4	30.94	51.5	205	220	6	8.5	18	4170	407	9	1510	137	5.42
240	47.4	28.69	60.4	224	240	6.5	9	21	5835	521	9.83	2077	173	5.87
260	54.1	27.17	69	244	260	6.5	9.5	24	7981	654	10.8	2788	214	6.36
280	61.2	25.98	78	264	280	7	10	24	10560	800	11.6	3664	262	6.85
300	69.8	24.36	88.9	283	300	7.5	10.5	27	13800	976	12.5	4733	316	7.30
320	74.2	23.45	94.6	301	300	8	11	27	16450	1090	13.2	4959	331	7.24
340	78.9	22.56	101	320	300	8.5	11.5	27	19550	1220	13.9	5185	346	7.18
360	83.7	21.62	107	339	300	9	12	27	23040	1360	14.7	5410	361	7.12
400	92.4	20.45	118	378	300	9.5	13	27	31250	1650	16.3	5861	391	7.06
450	99.7	19.86	127	425	300	10	13.5	27	41890	1970	18.2	6088	406	6.92
500	107	19.44	137	472	300	10.5	14	27	54640	2320	20	6314	421	6.79
550	120	18.08	153	522	300	11.5	15	27	72870	2790	21.8	6767	451	6.65
600	129	17.60	164	571	300	12	15.5	27	91870	3220	23.7	6993	466	6.53
650	138	17.17	176	620	300	12.5	16	27	113900	3676	25.5	7221	481	6.41
700	150	16.47	191	670	300	13	17	27	142700	4260	27.3	7673	512	6.34
800	172	15.47	218	770	300	14	18	30	208900	5426	30.9	8134	542	6.10
900	198	14.44	252	870	300	15	20	30	301100	6923	34.6	9041	603	5.99
1000	222	13.78	282	970	300	16	21	30	406500	8380	38	9501	633	5.80

# ROUND PROFILES

EN 10060

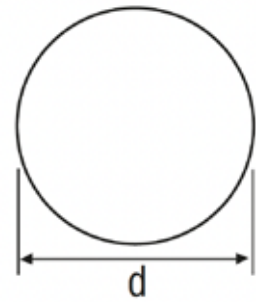

DIAMETER mm	WEIGHT kg/m
5	0.154
6	0.222
7	0.302
8	0.395
9	0.499
10	0.617
11	0.746
12	0.888
13	1.04
14	1.21
15	1.39
16	1.58
17	1.78
18	2.00
19	2.23
20	2.47
21	2.72
22	2.98
23	3.26
24	3.55
25	3.85
26	4.17
27	4.49
28	4.83
30	5.55

DIAMETER mm	WEIGHT kg/m
33	6.71
34	7.13
35	7.55
36	7.99
37	8.44
38	8.90
40	9.86
42	10.90
45	12.50
48	14.20
50	15.40
52	16.70
53	17.30
55	18.70
58	20.70
60	22.20
63	24.50
65	26.00
68	28.50
70	30.20
73	32.90
75	34.70
78	37.50
80	39.50
83	42.50
85	44.50

DIAMETER mm	WEIGHT kg/m
88	47.70
90	49.90
95	55.60
100	61.60
105	68.00
110	74.60
115	81.50
120	88.80
125	96.30
130	104
135	112
140	121
145	130
150	139
155	148
160	158
170	178
180	200
190	223
200	247
220	289
230	326.19
240	355.16
250	385.38
300	554.88
400	980.31
500	1531.7

# SQUARE PROFILES

EN 10059

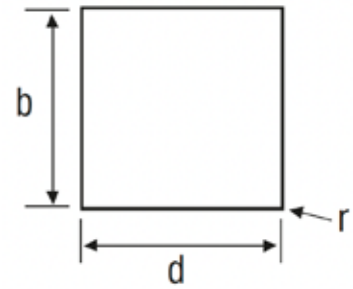

SIDE DESIGNATION (mm)	WEIGHT kg/m
5	0.196
6	0.283
7	0.385
8	0.502
9	0.636
10	0.785
11	0.950
12	1.13
13	1.33
14	1.54
15	1.77
16	2.01
18	2.54
19	2.83
20	3.14
22	3.80
25	4.91
26	5.31
28	6.15

SIDE DESIGNATION (mm)	WEIGHT kg/m
30	7.07
32	8.04
35	9.62
38	11.3
40	12.6
45	15.9
50	19.6
55	23.7
60	28.3
65	33.2
70	38.5
80	50.2
90	63.6
100	78.5
110	95.0
120	113
130	133
140	154
150	177

# FLAT PROFILES

EN 10058

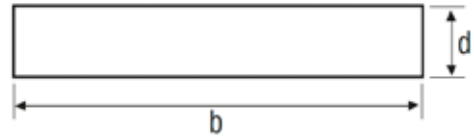

SIDE DESIGNATION (mm)	WEIGHT kg/m
10 x 3	0.236
4	0.314
5	0.393
6	0.471
12 x 3	0.283
4	0.377
5	0.471
6	0.565
8	0.754
14 x 3	0.330
4	0.440
5	0.550
6	0.659
8	0.879
15 x 3	0.351
4	0.468
5	0.585
6	0.702
8	0.936
10	1.170
16 x 3	0.377
4	0.502
5	0.628
6	0.754
8	1.000
10	1.260
18 x 3	0.424
4	0.565
5	0.707
6	0.848

SIDE DESIGNATION (mm)	WEIGHT kg/m
18 x 8	1.130
10	1.410
20 x 3	0.471
4	0.628
5	0.785
6	0.942
8	1.260
10	1.570
12	1.880
15	2.360
25 x 3	0.589
4	0.785
5	0.981
6	1.180
8	1.570
10	1.962
12	2.360
15	2.940
30 x 3	0.707
4	0.942
5	1.180
6	1.410
8	1.880
10	2.360
12	2.830
15	3.530
18	4.239
20	4.710

SIDE DESIGNATION (mm)	WEIGHT kg/m
• 35 x 3	0.824
4	1.100
5	1.370
6	1.650
8	2.200
10	2.750
12	3.300
15	4.120
18	4.945
20	5.500
25	6.870
• 40 x 3	0.942
4	1.260
5	1.570
6	1.880
8	2.510
10	3.140
12	3.770
15	4.710
18	5.652
20	6.280
25	7.850
• 30	9.420

• Not unified

# FLAT PROFILES

EN 10058

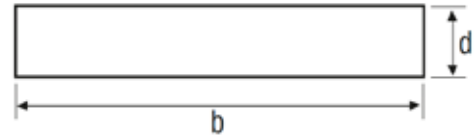

DESIGNAT. SIDE (mm)	WEIGHT kg/m
• 45 x 3	1.06
4	1.41
5	1.77
6	2.12
8	2.83
10	3.53
12	4.24
15	5.30
18	6.36
20	7.07
25	8.83
30	10.60
• 50 x 3	1.18
4	1.57
5	1.96
6	2.36
8	3.14
10	3.93
12	4.71
15	5.89
18	7.06
20	7.85
25	9.81
30	11.80
• 35	13.74
• 40	15.70

DESIGNAT. SIDE (mm)	WEIGHT kg/m
• 60 x 3	1.41
4	1.88
5	2.36
6	2.83
8	3.77
10	4.71
12	5.65
15	7.07
18	8.48
20	9.42
25	11.80
30	14.10
40	18.80
50	23.60

DESIGNAT. SIDE (mm)	WEIGHT kg/m
• 70 x 3	1.65
4	2.20
5	2.75
6	3.30
8	4.40
10	5.50
12	6.59
15	8.24
18	9.89
20	11.00
25	13.70
30	16.50
40	22.00
50	27.50
60	33.00

• Not unified

# FLAT PROFILES

EN 10058

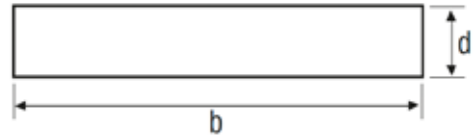

DESIGNAT. SIDE (mm)	WEIGHT kg/m
• 80 x 3	1.88
4	2.51
5	3.14
6	3.77
8	5.02
10	6.28
12	7.54
15	9.42
18	11.30
20	12.60
25	15.70
30	18.80
40	25.10
50	31.40
60	37.70
• 90 x 3	2.12
• 4	2.83
5	3.53
6	4.24
8	5.65
10	7.07
12	8.48
15	10.60
18	12.72
20	14.10
25	17.70
30	21.20
• 40	28.30
• 50	35.30
60	42.40
• 100 x 3	2.35
• 4	3.14
5	3.93
6	4.71
8	6.28
10	7.85
12	9.42

DESIGNAT. SIDE (mm)	WEIGHT kg/m
100 x 15	11.80
18	14.13
20	15.70
25	19.60
30	23.60
40	31.40
50	39.25
60	47.10
110 x 6	5.18
8	6.91
10	8.64
12	10.40
15	13.00
20	17.30
25	21.60
30	25.90
40	34.50
50	43.20
60	51.80
120 x 4	3.77
5	4.71
6	5.65
8	7.54
10	9.42
12	11.30
15	14.10
20	18.80
25	23.60
30	28.30
40	37.70
50	47.10
60	56.50
130 x 6	6.12
8	8.16

DESIGNAT. SIDE (mm)	WEIGHT kg/m
130 x 10	10.20
12	12.20
15	15.30
20	20.40
25	25.50
30	30.60
40	40.80
50	51.00
60	61.20
140 x 5	5.50
6	6.59
8	8.79
10	11.00
12	13.20
15	16.50
20	22.00
25	27.50
30	33.00
40	44.00
50	55.00
60	66.00
• 150 x 4	4.71
• 5	5.89
• 6	7.06
8	9.42
10	11.80
12	14.10
15	17.70
20	23.60
25	29.40
30	35.30
40	47.10
50	58.90
60	70.60

• Not unified

# FLAT PROFILES

EN 10058

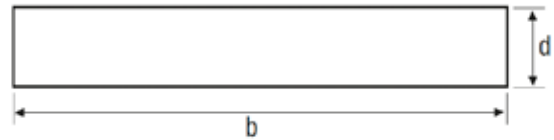

DESIGNAT. SIDE (mm)	WEIGHT kg/m
160 x 5	6.28
160 x 6	7.54
160 x 8	10.0
160 x 10	12.6
160 x 12	15.1
160 x 15	18.8
160 x 20	25.1
160 x 25	31.4
160 x 30	37.7
160 x 35	44.0
160 x 40	50.2
180 x 5	7.06
180 x 6	8.48
180 x 8	11.3
180 x 10	14.1
180 x 12	17.0
180 x 15	21.2
180 x 20	28.3
180 x 25	35.3
180 x 30	42.4
180 x 35	49.5
180 x 40	56.5
200 x 5	7.85
200 x 6	9.42
200 x 8	12.60
200 x 10	15.7
200 x 12	18.8
200 x 15	23.6
200 x 20	31.4
200 x 25	39.2
200 x 30	47.1
200 x 35	55.0
200 x 40	62.8
220 x 10	17.3
220 x 12	20.7
220 x 15	25.9
220 x 20	34.5
220 x 25	43.2
220 x 30	51.8
220 x 35	60.4
220 x 40	69.1

DESIGNAT. SIDE (mm)	WEIGHT kg/m
250 x 8	15.7
250 x 10	19.6
250 x 12	23.6
250 x 15	29.4
250 x 20	39.2
250 x 25	49.1
250 x 30	58.9
250 x 35	68.7
250 x 40	78.5
280 x 10	22.0
280 x 12	26.4
280 x 15	33.0
280 x 20	44.0
280 x 25	55.0
280 x 30	65.9
280 x 35	76.9
280 x 40	87.9
300 x 10	23.6
300 x 12	28.3
300 x 15	35.3
300 x 20	47.1
300 x 25	58.9
300 x 30	70.6
300 x 35	82.4
300 x 40	94.2
320 x 10	25.1
320 x 12	30.1
320 x 15	37.7
320 x 20	50.2
320 x 25	62.8
320 x 30	75.4
320 x 35	87.9
320 x 40	100.0
350 x 12	33.0
350 x 15	41.2
350 x 20	55.0
350 x 25	68.7
350 x 30	82.4
380 x 15	44.7
380 x 20	60.0
380 x 25	74.6
380 x 30	89.5
400 x 15	47.2
400 x 20	62.8
400 x 25	78.5
400 x 30	94.2

# ROUND CORNER ANGLE PROFILES

EN 10056

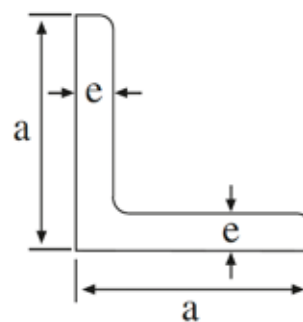

DESIGNAT. SIDE (mm)	WEIGHT kg/m
15 x 15 x 3	0.63
20 x 20 x 3	0.88
4	1.14
25 x 25 x 3	1.12
4	1.46
5	1.78
30 x 30 x 3	1.36
4	1.78
5	2.18
6	2.58
35 x 35 x 3	1.60
4	2.09
5	2.57
6	3.04
40 x 40 x 3	1.84
4	2.42
5	2.97
6	3.52
45 x 45 x 3	2.09
4	2.74
5	3.38
6	4.00
7	4.60

DESIGNAT. SIDE (mm)	WEIGHT kg/m
50 x 50 x 3	2.35
4	3.06
5	3.77
6	4.47
7	5.15
8	5.82
9	6.17
55 x 55 x 4	3.35
5	4.16
6	4.95
7	5.70
8	6.46
60 x 60 x 4	3.70
5	4.57
6	5.42
7	6.24
8	7.09
10	8.69
65 x 65 x 4	4.02
5	4.96
6	5.91
7	6.83
8	7.73
70 x 70 x 4	4.35
5	5.37
6	6.38
7	7.38
8	8.36
9	9.34
10	10.30
11	11.20



# ROUND CORNER ANGLE PROFILES

EN 10056

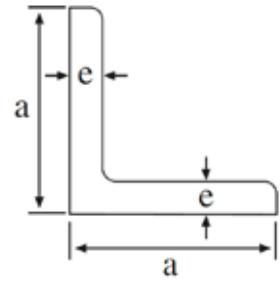

DESIGNAT. SIDE (mm)	WEIGHT kg/m
75 x 75 x 4	4.72
5	5.78
6	6.87
7	7.94
8	9.03
10	11.10
12	13.10
80 x 80 x 4	5.02
5	6.04
6	7.34
7	8.49
8	9.63
10	11.90
12	14.00
90 x 90 x 5	6.87
6	8.20
7	9.58
8	10.90
9	12.20
10	14.70
12	15.90
15	19.50
100 x 100	7.65
x 5	9.22
6	10.80
7	12.20
8	13.60
9	15.10
10	16.40
11	17.80
12	20.60
14	24.20
16	
110 x 110 x 6	11.20
7	13.00
8	13.50
10	16.60
12	19.70
14	22.80

DESIGNAT. SIDE (mm)	WEIGHT kg/m
120 x 120 x 6	11.20
7	13.00
8	14.75
10	18.20
11	19.30
12	21.60
13	23.30
14	25.00
15	26.60
18	31.50
130 x 130 x 6.5	12.90
7	13.90
8	15.95
9	17.85
10	19.80
11	21.60
12	23.60
14	27.20
16	30.90
140 x 140 x 13	27.50
14	29.50
15	31.40
17	35.30
150 x 150 x 12	27.20
13	29.40
14	31.60
15	33.80
16	35.90
18	40.10
20	44.20
160 x 160 x 15	36.20
17	40.70
19	45.10
180 x 180 x 15	41.00
16	43.50
18	48.60
20	53.70
22	58.60
200 x 200 x 15	45.8
16	48.50
18	54.30
20	59.90
22	65.60
24	71.10
26	76.60
28	82.00

# ROUND CORNER "L" PROFILES

EN 10056

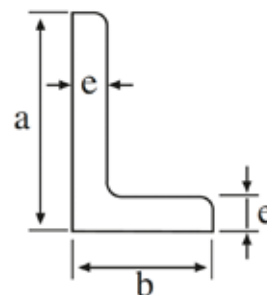

DESIGNAT. SIDE (mm)	WEIGHT kg/m
30 x 20 x 4	1.46
5	1.78
35 x 20 x 4	1.61
5	1.97
40 x 20 x 4	1.77
5	2.17
40 x 25 x 4	1.93
5	2.37
40 x 30 x 4	2.25
5	2.76
6	3.27
50 x 30 x 5	2.96
60 x 30 x 5	3.37
6	3.99
7	4.59
60 x 40 x 5	3.76
6	4.46
7	5.14
75 x 50 x 6	5.65
7	6.53
9	8.22
80 x 40 x 6	5.41
7	6.25
8	7.07
80 x 60 x 6	6.37
7	7.36
8	8.34
10	10.20
100 x 50 x 6	6.85
7	7.79
8	8.99
10	11.10
100 x 65 x 7	8.77
9	11.10
10	12.30
11	13.40

DESIGNAT. SIDE (mm)	WEIGHT kg/m
100 x 75 x 7	9.27
8	10.6
9	11.92
10	13.2
11	14.57
110 x 75 x 8	11.12
10	13.73
120 x 60 x 8	10.90
10	13.40
12	15.90
120 x 80 x 8	12.20
10	15.00
12	17.80
14	20.50
130 x 65 x 8	11.80
10	14.60
12	17.30
• 130 x 90 x 10	16.6
12	19.7
• 150 x 75 x 9	15.4
11	18.6
• 150 x 90 x 10	18.2
12	21.6
150 x 100 x 10	19.30
12	22.60
14	26.10
• 160 x 80 x 9	16.40
12	21.60
14	25.00
• 200 x 90 x 10	22.1
12	26.30
15	32.50
200 x 100 x 10	23.00
12	27.30
14	31.60
16	35.90
8	40.00

• Not unified

# SHARP CORNER "L" PROFILES

DIN 1022

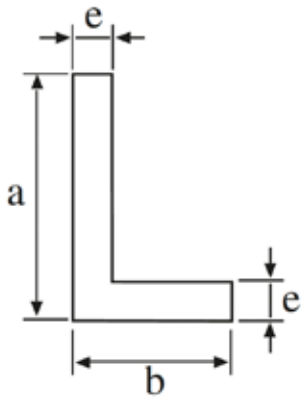

DESIGNAT. SIDE (mm)	WEIGHT kg/m
20 x 12 x 4	0.88
25 x 15 x 4.5	1.25
30 x 17.5 x 5	1.67
35 x 20 x 5.5	2.14
40 x 22 x 6	2.64
45 x 30 x 6.5	3.50
50 x 30 x 6	3.49
50 x 30 x 7	4.01

# "T" PROFILES

UNI 5681 / DIN 59051

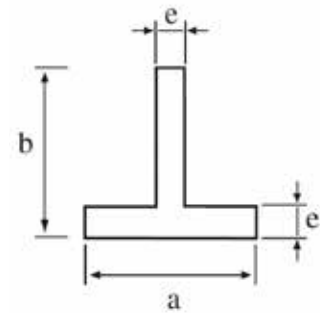

DESIGNAT. SIDE (mm)	WEIGHT kg/m
20 x 20 x 4	1.13
25 x 25 x 4.5	1.61
30 x 30 x 5	2.16
35 x 35 x 5.5	2.78
40 x 40 x 6	3.49

DESIGNAT. SIDE (mm)	WEIGHT kg/m
45 x 45 x 6.5	4.26
50 x 50 x 7	5.11
60 x 60 x 8	7.03
70 x 70 x 9	9.26
80 x 80 x 10	11.90

# ROUND CORNER "T" PROFILES

EN 10055

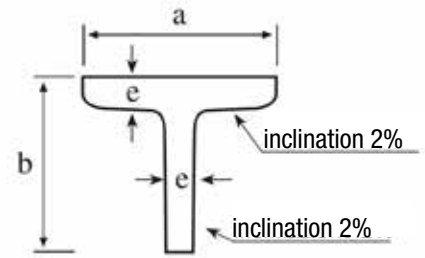

DESIGNAT. SIDE (mm)	WEIGHT kg/m
60 x 60 x 7	6.23
70 x 70 x 8	8.32
90 x 80 x 9	10.70
100 x 100 x 11	16.40
• 120 x 120 x 13	23.20

DIMENSIONAL TOLERANCES		
Nominal Dim. a	$a \leq 50$	$50 < a \leq 100$
Tolerances on a b	$\pm 1$	$\pm 1.5$
Tolerances on e	$\pm 0.5$	$\pm 0.75$

- Not unified

# "U" PROFILES SPECIAL SERIES

EURONORM 10025 - UNI EU 54

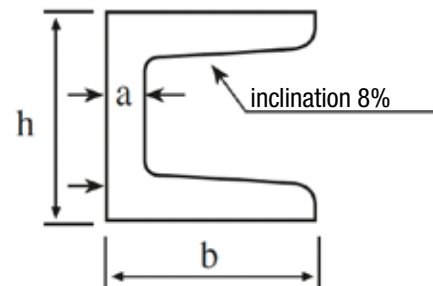

DESIGNATION mm	CORE THICKNESS mm	FLANGE THICKNESS mm	WEIGHT kg/m
• 25 x 12	4	4	1.30
30 x 15	• 5	• 5	1.98
• 35 x 17	5.5	5.5	2.52
40 x 20	6	6	3.23
50 x 25	6	6	4.15
60 x 30	6.5	6.5	5.45

- Not unified

# HANDRAIL THICKNESS 1.5 mm

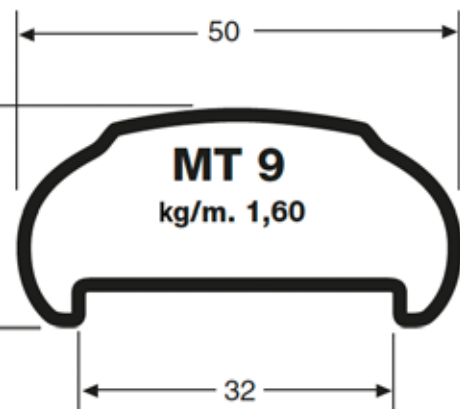
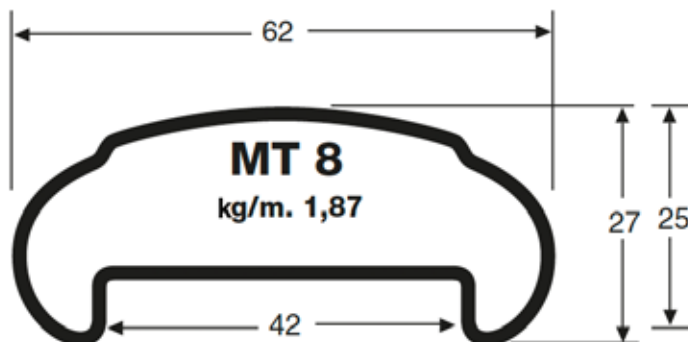
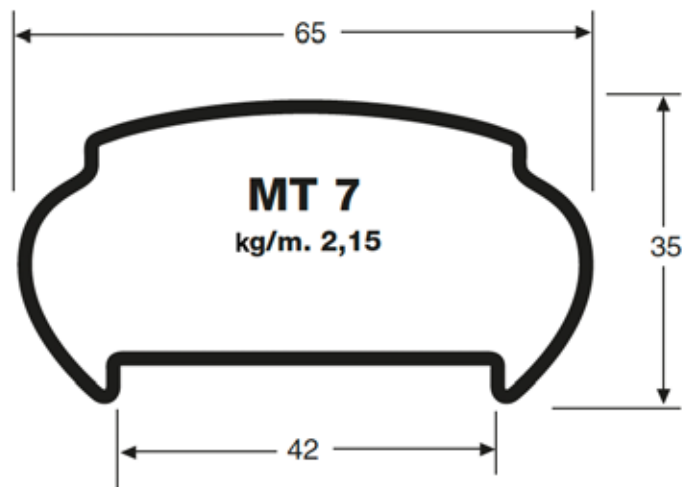
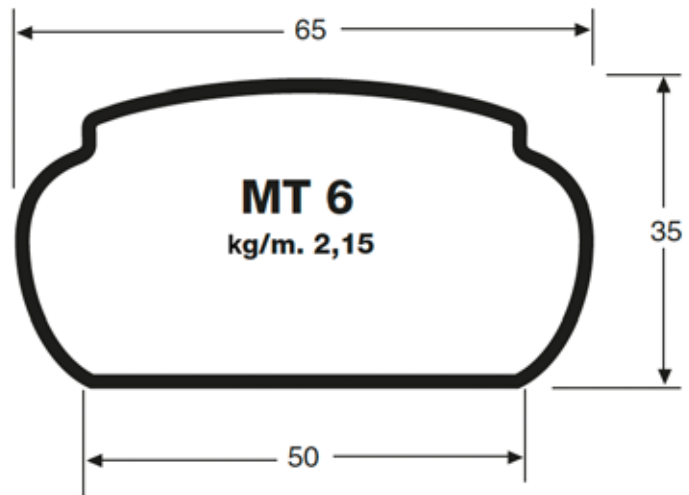
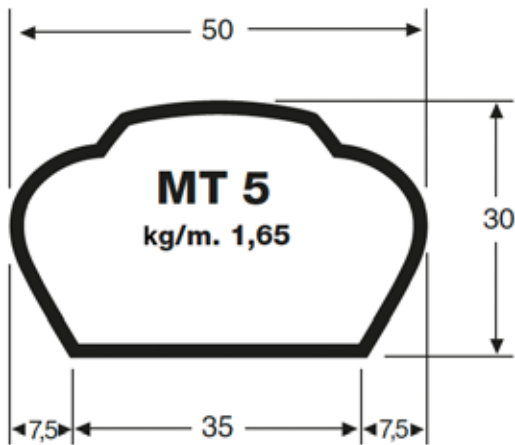



# HANDRAIL THICKNESS 1.5 mm

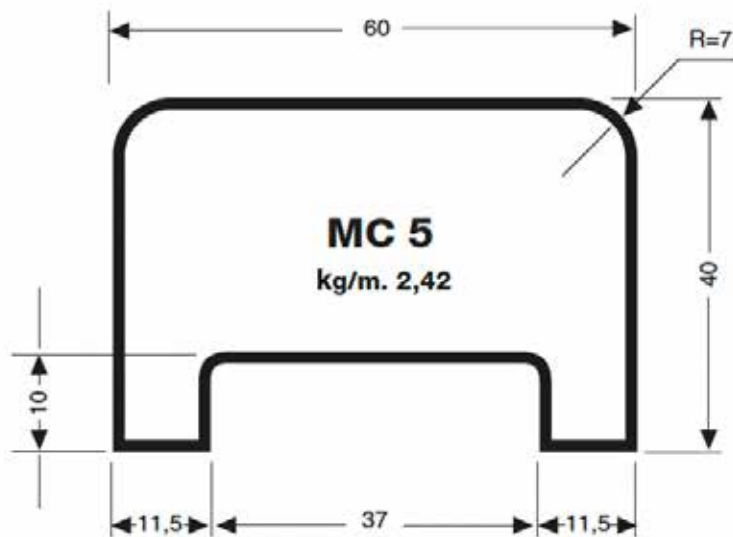
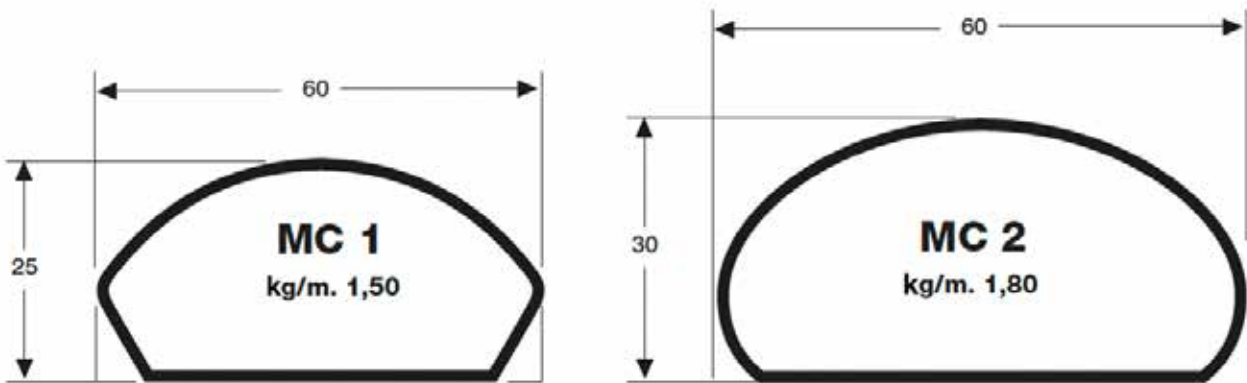

# MONORAILS AND TROLLEYS

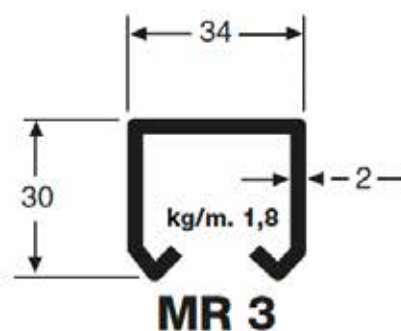
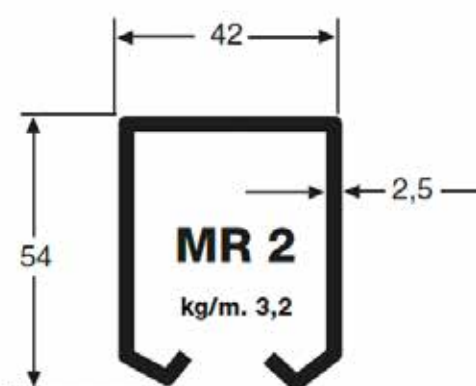
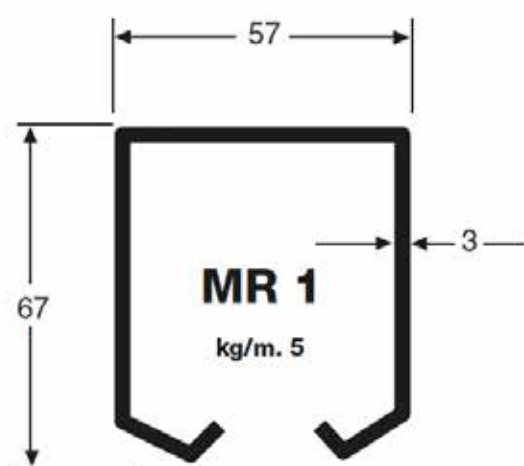



# MISCELLANEOUS SECTIONS

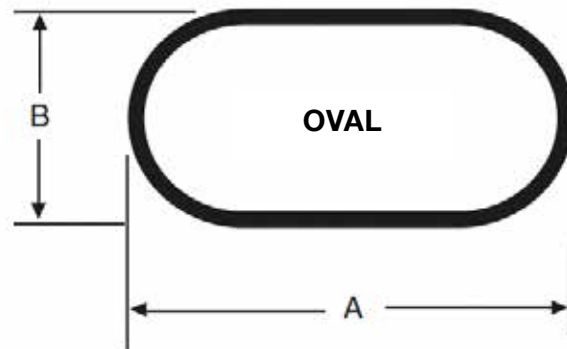

A	30	36	40	50	60*
B	15	18	20	25	30*
1.5	0.86	1.05	1.12	1.50	1.87
2	1.13	1.38	1.47	1.95	2.47
3				2.86	3.63





# ELECTRO-WELDED STRUCTURAL METALWORK PIPES

DIAMETER IN INCHES	OUTSIDE DIAMETER mm	THICKNESS mm	WEIGHT kg/m
3/8"	16.75	2	0.73
1/2"	21.25	2.2	1.03
3/4"	26.75	2.35	1.41
1"	33.3	2.6	1.97
1" ¼	42.25	3	2.90
1" ½	48.25	3	3.35
2"	60.3	3	4.24
2" ½	76.1	3	5.41
3"	88.9	3	6.36
3" ½	101.6	3	7.29
4"	114.3	3	8.23

# CIRCULAR PIPES FOR STRUCTURAL APPLICATIONS

EN 10219

ø (mm)	THCK. (mm)																			
		2.5	3	4	5	6	7	8	9	10	12.5	16	20							
88.9				8.38	10.4	12.29	14.2	16												
101.6				9.67	12	14.2	16.41	18.5												
108				10.3	12.7	15.1	17.4	19.7												
114.3				10.9	13.5	16	18.5	20.9												
127			7.68	9.17	15	17.9	20.7	23.5												
133			8.05	9.62	15.79	18.8	21.8	24.7												
139.7			8.46	10.1	16.6	19.8	22.9	26												
152.4				11.03	18.14	21.62	25	28.4												
159				11.5	19	22.6	26.2	29.8												
168.3				12.2	20.1	24	27.8	31.6												
177.8				12.9	21.3	25.4	29.5	33.5												
193.7				14.1	23.3	27.5	32.2	36.6												
219.1			16	21.2	26.4	31.5	36.6	41.6	46.6	51.5	63.7									
244.5				23.7	29.5	35.3	41	46.7	52.3	57.8	71.5									
273				26.5	33	39.5	45.9	52.3	58.6	64.9	80.3									
323.9				31.5	39.2	46.9	54.6	62.1	69.7	77.2	96	121.47								
335.6				32.7	40.8	48.8	56.7	64.6	72.5	80.3										
339.7				33.1	41.3	49.4	57.4	65.4	73.4	81.3										
355.6				34.7	43.2	51.7		68.6		85.2	106	134								
406.4				39.7	49.5	59.2	68.9	78.6	88.2	97.8	134	154								
457.2					55.8	66.8	77.7	88.6	99.5	110	137	174								
508					62	74.3	88.5	98.6	111	123	153	194								
558.8										135.15	168.41									
609.6								119		148	184	234	291							

# CIRCULAR PIPES FOR STRUCTURAL APPLICATIONS

EN 10219

DIMENSIONS mm	THICK. mm	WEIGHT kg/m
14	1	0.32
	1.2	0.38
	1.5	0.46
16	1	0.37
	1.2	0.43
	1.5	0.54
18	1	0.41
	1.2	0.49
	1.5	0.61
20	1	0.46
	1.2	0.55
	1.5	0.68
	2	0.88
22	1	0.51
	1.2	0.61
	1.5	0.75
	2	0.98
25	1	0.59
	1.2	0.70
	1.5	0.86
	2	1.13
28	1	0.66
	1.2	0.79
	1.5	0.98
	2	1.28
30	1	0.71
	1.2	0.85
	1.5	1.05
	2	1.38
	3	2.00
32	1	0.76
	1.2	0.91
	1.5	1.13
	2	1.48
35	1.2	1.00
	1.5	1.24
	2	1.63
	3	2.37
40	1.2	1.15
	1.5	1.42
	2	1.87
	3	2.74
42	1.2	1.21
	1.5	1.50
	2	1.97
	3	2.89
45	1.2	1.30
	1.5	1.61
	2	2.12
	3	3.11

DIMENSIONS mm	THICK. mm	WEIGHT kg/m
48	1.2	1.38
	1.5	1.72
	2	2.27
50	3	3.33
	1.5	1.79
	2	2.37
52	3	3.48
	1.5	1.87
55	2	2.47
	1.5	1.98
57	2	2.61
	1.5	2.05
	3	2.71
60	3	4.00
	1.5	2.16
	2	2.86
	4	5.52
65	1.5	2.35
	2	3.11
70	1.5	2.53
	2	3.35
	3	4.96
	4	6.51
76	1.5	2.76
	2	3.65
	3	5.40
	4	7.10
80	1.5	2.90
	2	3.85
	3	5.70
83	1.5	3.01
	2	4.00
	3	5.92
	4	7.79
89	1.5	3.24
	2	4.29
	3	6.36
102	2	4.93
	3	7.32
108	2	5.23
	3	7.77
121	2	5.87
	3	8.73
	4	11.50
130	2	6.31

# SQUARE PIPES FOR STRUCTURAL APPLICATIONS

EN 10219

DIMENSIONS mm	THICK. mm	WEIGHT kg/m	DIMENSIONS mm	THICK. mm	WEIGHT kg/m	DIMENSIONS mm	THICK. mm	WEIGHT kg/m
10 x 10	1.2	0.33	90 x 90	2	5.45	200 x 200	3	18.40
12 x 12	1.2	0.40		3	8.01		4	24.30
15 x 15	1.2	0.52		4	10.50		5	30.10
	1.5	0.63		5	12.80		6	35.80
	2	0.73	100 x 100	2	6.07		8	46.5
20 x 20	1.5	0.87		3	8.96		10	57
	2	1.05		4	11.70	12.5	68.3	
	3	1.42		110 x 110	5	14.40	220 x 220	4
25 x 25	1.5	1.11			6	17.00		5
	2	1.36	7		19.10	6		39.60
3	1.89	8	21.4		8	51.5		
30 x 30	1.5	1.34	120 x 120	3	9.90	10		63.2
	2	1.68		4	13.00	12.5	76.2	
	3	2.36	140 x 140	150 x 150	3	10.80	6	45.2
	4	2.94			4	14.20	8	59.1
35 x 35	1.5	1.58			5	17.50	10	72.7
	2	1.99			6	20.70	12.5	88
	3	2.83	8		26.41	16	109	
4	3.57	160 x 160	175 x 175	4	16.76	4	31.80	
40 x 40	1.5			1.81	5	20.69	5	39.50
	2			2.31	6	24.52	6	47.10
	3			3.30	8	31.43	7	54.30
	4	4.20		10	38.12	8	61.60	
45 x 45	1.5	2.05	180 x 180	3	13.70	10	75.8	
	2	2.62		4	18.00	12.5	91.9	
	3	3.77		5	22.30	8	71.6	
50 x 50	1.5	2.28		6	26.40	10	88.4	
	2	2.93	8	33.95	16	134		
	3	4.25	10	41.26	12.5	108		
	4	5.45	325 x 325	4	23.83	16	134	
5	6.56	5		28.29	4	36.90		
60 x 60	1.5	2.76		6	28.29	5	45.80	
	2	3.56		8	36.46	6	54.70	
	3	5.19	10	44.4	7	63.10		
	4	6.71	350 x 350	3	16.00	8	71.60	
	5	8.13		4	21.20	6	64.08	
70 x 70	1.5	3.23		5	26.20	8	84.2	
	2	4.19	6	31.10	10	104		
	3	6.13	400 x 400	12.5	32.1	12.5	127	
	4	7.97		6	41.5	16	159	
	5	9.70		8	50.7	8	96.75	
	6	11.33		10	60.5	10	120	
80 x 80	2	4.82	500 x 500			12.5	147	
	3	7.07				16	184	
	4	9.22				20	225.16	
	5	11.30				12.5	186.08	
	6	13.20				16	234.54	
8	16.36	20	287.96					

# RECTANGULAR PIPES FOR STRUCTURAL APPLICATIONS

EN 10219

DESIGNAT. SIDE (mm)	THICK. mm	WEIGHT kg/m	DIMENSIONS mm	THICK. mm	WEIGHT kg/m	DIMENSIONS mm	THICK. mm	WEIGHT kg/m
15 x 10	1.2	0.43	45 x 20	1.5	1.46	70 x 20	1.5	2.05
	1.5	0.51		2	1.83		2	2.62
20 x 10	1.2	0.52		3	2.60		3	3.77
	1.5	0.63	40 x 30	1.5	1.58	70 x 25	1.5	2.17
2	0.74	2		1.99	2		2.78	
20 x 15	1.2	0.61		3	2.83		3	4.01
	1.5	0.75	45 x 20	1.5	1.46	70 x 30	1.5	2.28
2	0.89	2		1.83	2		2.93	
25 x 10	1.2	0.61		3	2.60		3	4.25
	1.5	0.75	50 x 10	1.5	1.34		4	5.45
2	0.89	2		1.68	70 x 35	1.5	2.40	
25 x 15	1.2	0.70	50 x 15	1.5		1.46	2	3.09
	1.5	0.87		2	1.83	3	4.48	
2	1.05	50 x 20	1.5	1.58	70 x 40	1.5	2.52	
30 x 10	1.2		0.70	2		1.99	2	3.25
	1.5	0.87	3	2.83		3	4.72	
2	1.05	50 x 25	1.5	1.70		4	6.08	
30 x 15	1.2		0.80	2	2.15	70 x 50	1.5	2.76
	1.5	0.99	3	3.07	2		3.56	
2	1.21	50 x 30	1.5	1.81	3		5.19	
3	1.65		2	2.31	4	6.71		
30 x 20	1.2		0.89	3	3.30	80 x 15	1.5	2.17
	1.5	1.11	50 x 40	1.5	2.05		2	2.78
2	1.36	2		2.62	80 x 20	1.5	2.28	
3	1.89	3		3.77		2	2.93	
35 x 10	1.5	0.99		4		4.83	3	4.25
	2	1.21	60 x 10	1.5	1.58	80 x 30	1.5	2.52
35 x 15	1.5	1.11		2	1.99		2	3.25
	2	1.36	60 x 15	1.5	1.70		3	4.72
35 x 20	1.2	0.99		2	2.15		4	6.08
	1.5	1.22	60 x 20	1.5	1.81	1.5	2.76	
	2	1.52		2	2.31	2	3.56	
3	2.13	3		3.30	3	5.19		
40 x 10	1.2	0.90	60 x 25	1.5	1.93	4	6.71	
	1.5	1.11		2	2.46	5	8.13	
	2	1.36		3	3.54	80 x 50	1.5	2.99
40 x 15	1.2	0.99	60 x 30	1.5	2.05		2	3.88
	1.5	1.22		2	2.62		3	5.66
2	1.52	3		3.77	4		7.34	
40 x 20	1.2	1.09		4	4.83	80 x 60	1.5	3.23
	1.5	1.34	60 x 40	1.5	2.28		2	4.19
	2	1.68		2	2.93		3	6.13
3	2.57	5	5.45	4	7.97			
40 x 25	1.5	1.46	4	6.56	5		9.7	
	2	1.83	60 x 50	2	3.25	90 x 30	1.5	2.76
	3	2.60		3	4.72		2	3.56
40 x 30	1.5	1.58	2	3	3		5.19	
	2	1.99			4		6.71	
3	2.83							

DIMENSIONS mm	THICK. mm	WEIGHT kg/m
90 x 50	3	6.13
	4	7.97
100 x 20	1.5	2.76
	2	3.56
	3	5.19
100 x 30	1.5	2.99
	2	3.88
	3	5.66
	4	7.34
100 x 40	1.5	3.23
	2	4.19
	3	6.13
	4	7.97
	5	9.7
100 x 50	1.5	3.46
	2	4.50
	3	6.60
	4	8.59
	5	10.48
100 x 60	2	4.82
	3	7.07
	4	9.22
	5	11.27
	6	13.21
	8	16.36
100 x 80	3	8.01
	4	10.50
	5	12.84
	6	15.1
110 x 50	2	4.82
	3	7.07
120 x 30	2	4.50
	3	6.60
120 x 40	2	4.82
	3	7.07
	4	9.22
120 x 60	2	5.45
	3	8.01
	4	10.50
	5	12.80
	6	15.10
	8	18.87
120 x 80	2	6.07
	3	8.96
	4	11.70
	5	14.40
	6	16.98
	8	21.4
120 x 100	4	12.99
	5	15.98
	6	18.87
	8	23.9

DIMENSIONS mm	THICK. mm	WEIGHT kg/m
130 x 50	2	5.45
	3	8.01
	4	10.50
130 x 60	2	5.76
	3	8.48
140 x 60	3	8.96
	4	11.70
140 x 70	3	9.43
	4	12.40
140 x 80	3	9.90
	4	13.00
	5	15.98
	6	18.87
150 x 30	2	5.45
	3	8.01
150 x 40	2	5.76
	3	8.48
150 x 50	2	6.07
	3	8.96
	4	11.70
150 x 100	3	11.30
	4	14.90
	5	18.33
	6	21.69
160 x 50	2	6.39
	3	9.43
160 x 80	3	10.80
	4	14.20
	5	17.50
	6	20.70
	8	26.41
160 x 120	4	16.76
	5	20.69
	6	24.52
	8	31.43
180 x 60	3	10.80
	4	14.20
	5	17.50
180 x 80	3	11.80
	4	15.50
180 x 100	4	16.76
	5	20.69
	6	24.52
	8	31.43

DIMENSIONS mm	THICK. mm	WEIGHT kg/m
200 x 100	3	13.70
	4	18.00
	5	22.30
	6	26.4
	8	33.95
200 x 120	10	41.26
	5	23.83
	6	28.29
250 x 100	8	36.46
	10	44.4
	3	16.00
250 x 150	4	21.20
	6	31.10
	6	35.8
260 x 180	8	46.5
	10	57
	12.5	68.3
	6	39.6
300 x 150	8	51.5
	10	63.2
	12.5	76.2
	4	27.40
300 x 200	5	34.00
	6	40.50
	8	52.8
	10	64.8
	12.5	78.1
350 x 250	6	45.2
	8	59.1
	10	72.7
	12.5	88
400 x 200	16	109
	8	71.6
	10	88.4
	12.5	108
	16	134
500 x 200	20	162.36
	8	71.6
	10	88.4
	12.5	108
500 x 300	16	134
	20	162.36
	6.3	66.92
	8	84.2
600 x 400	10	104
	12.5	127
	16	159
	8	96.75
600 x 400	10	120
	12.5	147
	16	184
	20	225.16
600 x 400	12.5	186.08
	16	234.54
	20	287.96

# COMMERCIAL GAS PIPES

## (NORMAL SERIES) THREADED WITH COUPLING

EN 10255

INCHES	OUT. DIAM.	SEAMLESS			WELDED		
		THICKNESS	WEIGHT PER M kg/m		THICKNESS	WEIGHT PER M kg/m	
			mm	WITHOUT COUPL.		WITH COUPL.	mm
1/8	10.2	1.80	0.369	0.372	1.80	0.361	0.364
1/4	13.5	2.00	0.573	0.577	1.80	0.517	0.521
3/8	17.2	2.00	0.747	0.753	1.80	0.674	0.680
1/2	21.3	2.35	1.10	1.11	2.00	0.952	0.961
3/4	26.9	2.35	1.41	1.42	2.35	1.41	1.42
1	33.7	2.90	2.21	2.23	2.65	2.01	2.03
1 1/4	42.4	2.90	2.84	2.87	2.65	2.58	2.61
1 1/2	48.3	2.90	3.26	3.30	2.90	3.25	3.29
2	60.3	3.25	4.56	4.63	2.90	4.11	4.18
2 1/2	76.1	3.25	5.81	5.93	3.25	5.80	5.92
3	88.9	3.65	7.65	7.82	3.25	6.81	6.98
3 1/2	101.6	3.65	8.77	8.95	3.65	8.74	8.92
4	114.3	4.05	11.00	11.30	3.65	9.89	10.20

# SQUARE STRUCTURAL PIPES

**HOT-ROLLED STRUCTURAL PIPES ACCORDING TO EN 10210**  
**S 275J0H QUALITY**  
**S 355J2H QUALITY**

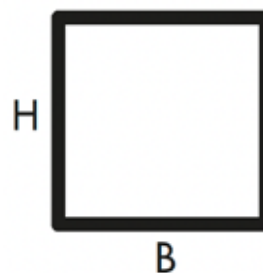

DIMENSIONS (mm)	THICKNESS (mm)												
	BxH	2	3	4	5	6	7	8	10	12	14	16	20
20x20	1.10	-	-	-	-	-	-	-	-	-	-	-	-
25x25	1.41	2.00	2.50	2.93	-	-	-	-	-	-	-	-	-
30x30	1.72	2.47	3.13	3.71	4.22	-	-	-	-	-	-	-	-
35x35	2.04	2.94	3.76	4.50	5.16	-	-	-	-	-	-	-	-
40x40	2.35	3.41	4.39	5.28	6.10	6.84	7.50	-	-	-	-	-	-
45x45	2.67	3.88	5.01	6.07	7.04	7.94	8.76	-	-	-	-	-	-
50x50	2.98	4.35	5.64	6.85	7.99	9.04	10.00	11.70	-	-	-	-	-
60x60	3.61	5.29	6.90	8.42	9.87	11.20	12.50	14.90	-	-	-	-	-
70x70	4.24	6.24	8.15	9.99	11.80	13.40	15.00	18.00	20.60	-	-	-	-
80x80	4.86	7.18	9.41	11.60	13.60	15.60	17.50	21.10	24.40	-	-	-	-
90x90	5.49	8.12	10.70	13.10	15.50	17.80	20.10	24.30	28.20	-	-	-	-
100x100	6.12	9.06	11.90	14.70	17.40	20.00	22.60	27.40	31.90	36.20	-	-	-
110x110	-	10.00	13.20	16.30	19.30	22.20	25.10	30.60	35.70	-	-	-	-
120x120	-	10.90	14.40	17.80	21.20	24.40	27.60	33.70	39.50	-	-	-	-
130x130	-	11.90	15.70	19.40	23.10	26.60	30.10	36.80	43.20	-	-	-	-
140x140	-	12.80	16.90	21.00	24.90	28.80	32.60	40.00	47.00	53.70	60.10	-	-
150x150	-	13.80	18.20	22.60	26.80	31.00	35.10	43.10	50.80	58.10	65.20	-	-
160x160	-	14.70	19.50	24.10	28.70	33.20	37.60	46.30	54.60	62.50	70.20	-	-
175x175	-	16.10	21.30	26.50	31.50	36.50	41.40	51.00	-	-	-	-	-
180x180	-	22.00	27.30	32.50	37.60	42.70	52.50	62.10	71.30	80.20	-	-	-
200x200	-	-	24.50	30.40	36.20	42.00	47.70	58.80	69.60	80.10	90.30	-	-
220x220	-	-	27.00	33.50	40.00	46.40	52.70	65.10	77.20	88.90	100.00	-	-
250x250	-	-	30.80	38.30	45.70	53.00	60.30	74.50	88.50	102.00	115.00	-	-
260x260	-	-	32.00	39.80	47.60	55.20	62.80	77.70	92.20	106.00	-	-	-
300x300	-	-	-	46.10	55.10	64.00	72.80	90.20	107.00	124.00	141.00	-	-
325x325	-	-	-	50.00	59.80	69.50	79.10	98.10	-	-	-	-	-
350x350	-	-	-	-	64.50	-	85.40	106.00	126	146.00	166.00	-	-
400x400	-	-	-	-	-	-	97.90	122.00	145.00	168.00	191.00	235.00	-

Other sizes and thicknesses on request



# RECTANGULAR STRUCTURAL PIPES

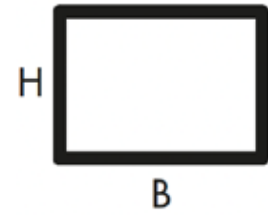

**HOT-ROLLED STRUCTURAL PIPES ACCORDING TO EN 10210**  
**S 275J0H QUALITY**  
**S 355J2H QUALITY**

DIMENSIONS (mm)	THICKNESS (mm)											
	BxH	2	3	4	5	6	7	8	10	12	14	16
40x30	2.04	2.94	3.76	4.50	5.16	-	-	-	-	-	-	-
50x30	2.35	3.41	4.39	5.28	6.10	-	-	-	-	-	-	-
50x40	2.67	3.88	5.01	6.07	7.04	7.94	8.76	-	-	-	-	-
60x30	2.67	3.88	5.01	6.07	7.04	-	-	-	-	-	-	-
60x40	2.98	4.35	5.64	6.85	7.99	9.04	10.00	-	-	-	-	-
60x50	3.29	4.82	6.27	7.64	8.93	10.10	11.30	-	-	-	-	-
65x45	-	-	-	-	8.93	-	-	-	-	-	-	-
70x30	2.98	4.35	5.64	6.85	7.99	9.04	10.00	-	-	-	-	-
70x40	3.29	4.82	6.27	7.64	8.93	10.10	11.30	13.30	-	-	-	-
70x50	3.61	5.29	6.90	8.42	9.07	11.20	12.50	14.90	-	-	-	-
70x60	-	5.76	7.93	9.21	10.80	12.30	13.80	16.40	-	-	-	-
80x30	3.29	4.82	6.27	-	-	-	-	-	-	-	-	-
80x40	3.61	5.29	6.90	8.42	9.87	11.20	12.50	14.90	-	-	-	-
80x50	3.92	5.76	7.53	9.21	10.80	12.30	13.80	16.40	-	-	-	-
80x60	4.24	6.24	8.15	9.99	11.80	13.40	15.00	18.00	-	-	-	-
90x30	3.61	5.29	6.90	-	-	-	-	-	-	-	-	-
90x40	3.92	5.76	7.53	-	-	-	-	-	-	-	-	-
90x50	4.24	6.24	8.15	9.99	11.80	13.40	15.00	18.00	-	-	-	-
90x60	4.55	6.71	8.78	-	12.70	-	-	-	-	-	-	-
100x30	3.92	5.76	7.53	9.21	10.80	12.30	13.80	16.40	-	-	-	-
100x40	4.24	6.24	8.15	9.99	11.80	13.40	15.00	18.00	-	-	-	-
100x50	4.55	6.71	8.78	10.80	12.70	14.50	16.30	19.60	-	-	-	-
100x60	4.86	7.18	9.41	11.60	13.60	15.60	17.50	21.10	-	-	-	-
100x70	5.18	7.65	10.00	12.30	14.60	16.70	18.80	22.70	-	-	-	-
100x80	5.49	8.12	10.70	12.10	15.50	17.80	20.10	24.30	28.20	-	-	-
100x90	-	8.59	11.30	13.90	16.50	18.90	21.30	25.80	30.10	-	-	-
110x50	4.86	7.18	9.41	11.60	13.60	15.60	-	-	-	-	-	-
110x60	-	7.65	10.00	12.30	14.60	16.70	18.80	22.70	-	-	-	-
110x70	-	8.12	10.70	13.10	15.50	17.80	20.10	24.30	-	-	-	-
110x80	-	8.59	11.30	13.90	16.50	18.90	21.30	25.80	30.10	-	-	-
120x30	4.55	6.71	8.78	-	-	-	-	-	-	-	-	-

Other sizes and thicknesses on request

DIMENSIONS (mm)	THICKNESS (mm)											
	BxH	2	3	4	5	6	7	8	10	12	14	16
120x40	4.86	7.18	9.41	11.60	13.60	15.60	17.50	21.10	-	-	-	-
120x50	-	7.65	10.00	12.30	14.60	16.70	18.80	22.70	-	-	-	-
120x60	5.49	8.12	10.70	13.10	15.50	17.80	20.10	24.30	-	-	-	-
120x70	-	8.59	11.30	13.90	16.50	18.90	21.30	25.80	-	-	-	-
120x80	6.12	9.06	11.90	14.70	17.40	20.00	22.10	27.40	31.90	-	-	-
120x100	-	10.00	13.20	16.30	19.30	22.20	25.10	30.60	35.70	-	-	-
130x50	54.9	8.12	10.70	13.10	15.50	-	-	-	-	-	-	-
130x60	5.81	8.59	11.30	-	-	-	-	-	-	-	-	-
140x40	5.49	8.12	10.70	13.10	15.50	17.80	20.10	24.30	-	-	-	-
140x50	5.81	8.59	11.30	-	-	-	-	-	-	-	-	-
140x60	6.12	9.06	11.90	14.70	17.40	20.00	22.60	27.40	-	-	-	-
140x70	-	9.53	12.60	15.50	18.30	21.10	23.80	29.00	33.80	-	-	-
140x80	-	10.00	13.20	16.30	19.30	22.20	25.10	30.60	35.70	-	-	-
140x90	-	10.50	13.80	17.10	20.20	23.30	26.30	32.10	37.60	-	-	-
150x30	5.49	8.12	10.70	-	-	-	-	-	-	-	-	-
150x40	5.81	8.59	11.30	-	-	-	-	-	-	-	-	-
150x50	6.12	9.06	11.90	14.70	17.40	20.00	22.00	27.40	-	-	-	-
150x60	-	9.53	12.60	15.50	18.30	21.10	23.80	29.00	-	-	-	-
150x75	-	-	-	16.70	19.80	22.80	25.70	31.30	-	-	-	-
150x80	7.06	10.50	-	-	-	-	-	-	-	-	-	-
150x100	-	11.40	15.10	18.60	22.10	25.50	28.90	35.30	41.40	-	-	-
160x50	-	9.53	12.60	15.50	18.30	-	-	-	-	-	-	-
160x60	-	10.00	13.20	16.30	19.30	22.20	25.10	30.60	-	-	-	-
160x80	-	10.90	14.40	17.80	21.20	24.40	27.60	33.70	39.50	-	-	-
160x90	-	11.40	15.10	18.60	22.10	25.50	28.90	35.30	41.40	-	-	-
160x120	-	-	-	-	24.90	-	32.60	-	-	-	-	-
180x60	-	10.90	14.40	17.80	21.20	24.40	27.60	33.70	39.50	-	-	-
180x70	-	11.40	15.10	18.60	22.10	25.50	28.90	35.30	41.40	-	-	-
180x80	-	11.90	15.70	19.40	23.10	26.60	30.10	36.80	43.20	-	-	-
180x100	-	-	16.90	21.00	24.90	28.80	32.60	40.00	47.00	53.70	60.10	-
180x120	-	-	18.20	22.60	26.80	-	35.10	43.10	-	-	-	-
180x140	-	-	19.50	24.10	28.70	-	37.60	46.30	-	-	-	-
200x100	-	13.80	18.20	22.60	26.80	31.00	35.10	43.10	50.80	58.10	65.20	-
200x120	-	-	19.50	24.10	28.70	33.20	37.60	46.30	54.60	62.50	70.20	-
200x150	-	16.10	21.30	26.50	31.50	36.50	41.40	51.00	60.20	-	-	-
220x80	-	-	18.20	22.60	26.80	-	35.10	43.10	-	-	-	-
220x100	-	-	-	24.10	28.70	-	37.60	46.30	-	-	-	-
220x120	-	-	-	25.70	30.60	35.40	40.20	49.40	58.30	66.90	75.20	-
220x140	-	-	-	27.30	32.50	37.60	42.70	52.50	62.10	-	-	-
250x100	-	16.10	21.30	26.50	31.50	36.50	41.40	51.00	60.20	-	-	-
250x150	-	-	24.50	30.40	36.20	42.00	47.70	58.80	69.60	80.10	90.30	-

Other sizes and thicknesses on request

DIMENSIONS (mm)	THICKNESS (mm)										
	2	3	4	5	6	7	8	10	12	14	16
260x140	-	-	-	30.40	36.20	-	47.70	58.80	69.60	80.10	90.30
260x180	-	-	-	33.50	40.00	-	52.70	65.10	77.20	88.90	100.00
300x100	-	-	24.50	30.40	36.20	42.00	47.70	58.80	69.60	-	-
300x150	-	-	27.60	34.30	41.00	47.50	54.00	66.70	79.00	91.10	-
300x200	-	-	30.80	38.30	45.70	53.00	60.30	74.50	88.50	102.00	115.00
350x150	-	-	-	38.30	45.70	-	60.30	74.50	88.50	-	-
350x250	-	-	-	-	55.10	-	72.80	90.20	107.00	124.00	-
400x100	-	-	-	38.30	45.70	-	60.30	74.50	88.50	-	-
400x200	-	-	-	46.10	55.10	64.00	72.80	90.20	107.00	124.00	141.00
400x250	-	-	-	50.00	59.80	69.50	79.10	-	-	-	-
400x300	-	-	-	-	64.50	-	85.40	106.00	126.00	146.00	-
450x250	-	-	-	-	64.50	-	85.40	106.00	126.00	146.00	166.00
500x200	-	-	-	-	-	-	85.40	106.00	145.00	-	-
500x300	-	-	-	-	-	-	97.90	122.00	145.00	-	191.00

Other sizes and thicknesses on request

# TUBULAR PROFILES FOR DOORS AND WINDOWS

THICKNESS 1.5 mm

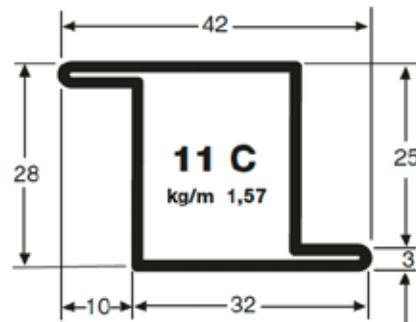
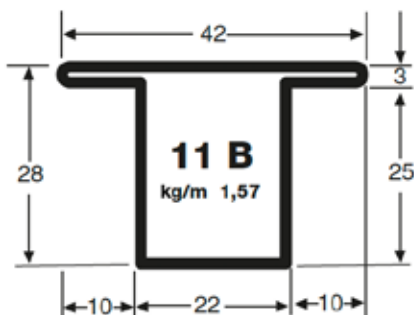
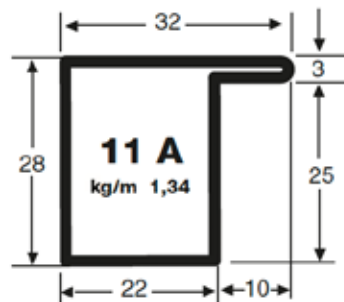
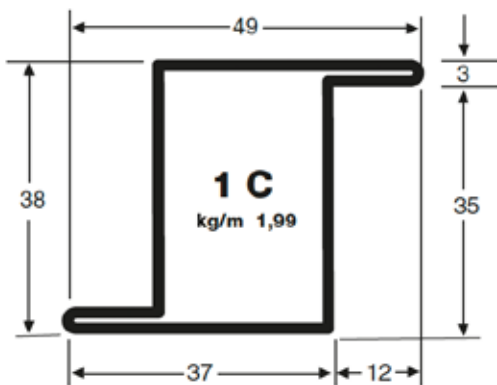
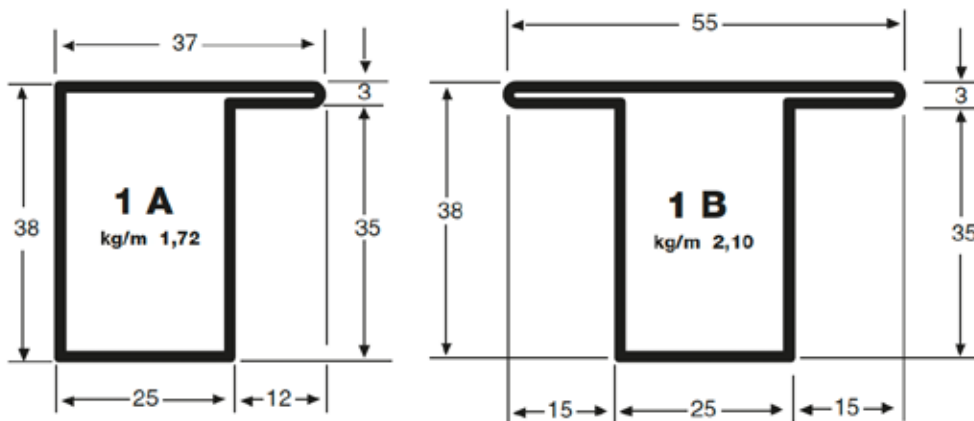

# TUBULAR PROFILES FOR DOORS AND WINDOWS

THICKNESS 1.5 mm

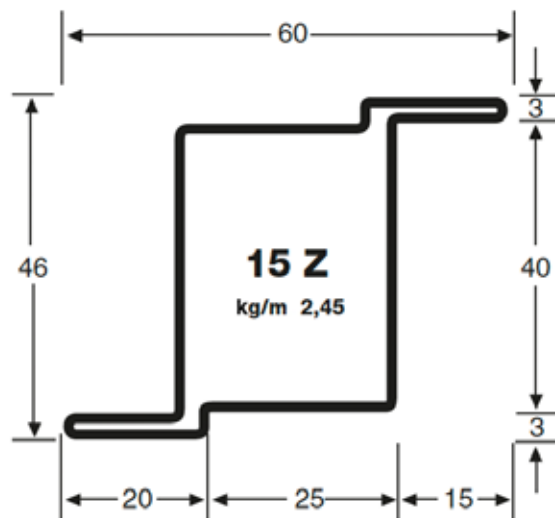
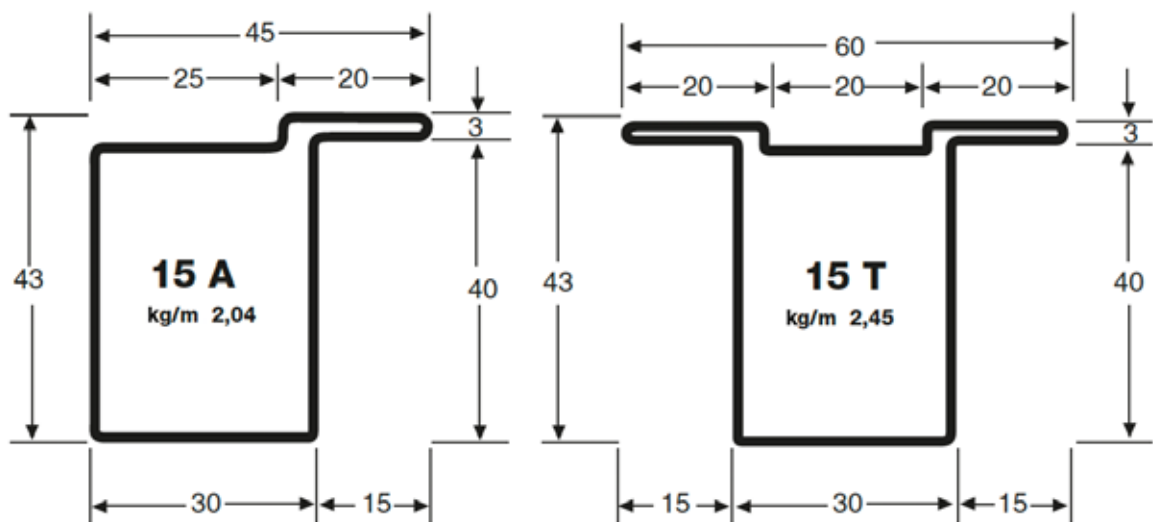

# TUBULAR PROFILES FOR DOORS AND WINDOWS

THICKNESS 1.5 mm (LIGHTWEIGHT)

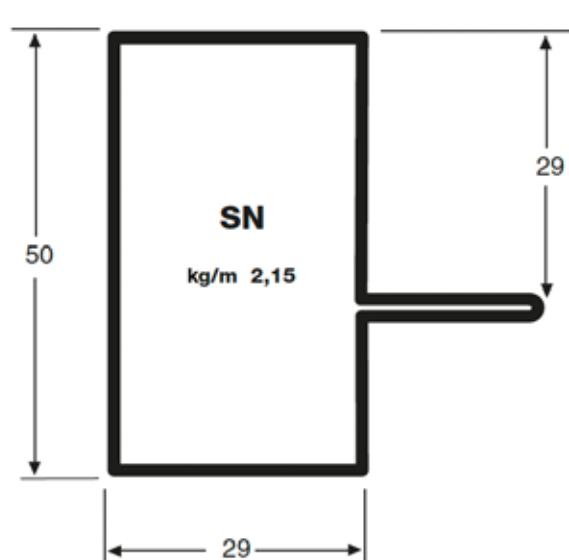
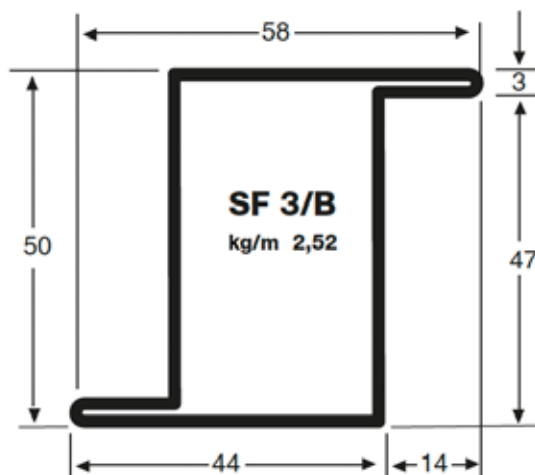
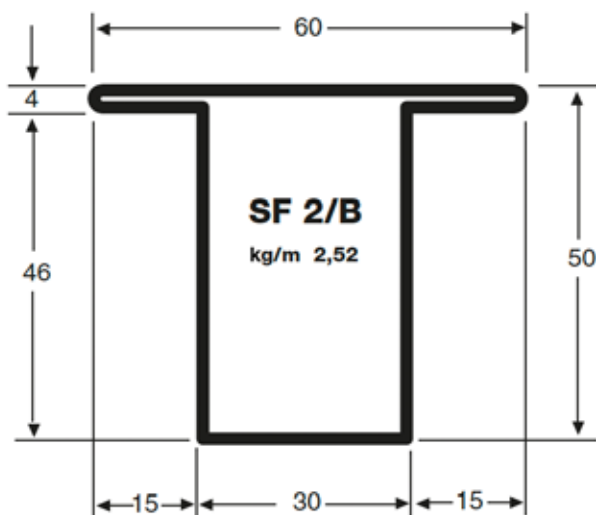
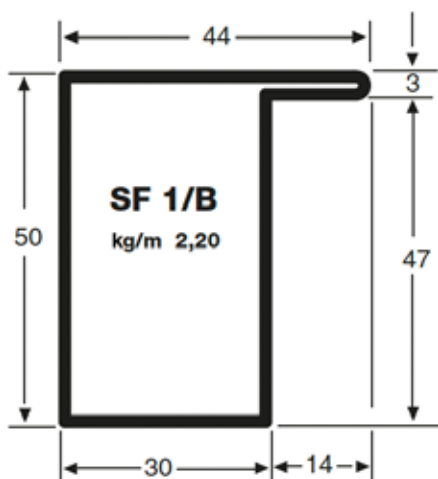

# RAILS FOR SLIDING SURFACES

## BURBACK RAILS (R70 QUALITY)

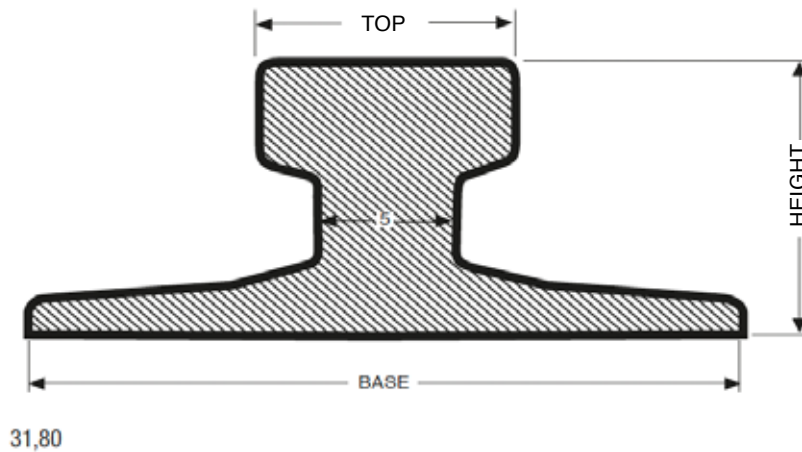

DIN DIMENSIONS		PROFILE NO.	WEIGHT kg/ml	DIMENSIONS (mm)		
				HEIGHT	BASE	TOP
KS 22	A 45	1	22.10	55	125	45
KS 32	A 55	2	31.80	65	150	55
KS 43	A 65	3	43.10	75	175	65
KS 56	A 75	4	56.20	85	200	75
KS 75	A 100	5	74.30	95	200	100
KS 101	A 120	6	100.00	105	220	120
-	A 150	7	150.30	150	220	150



# MANNI SIPRE

STEEL CO-CREATION

[www.mannisipre.it](http://www.mannisipre.it)

<p><b>Headquarters:</b> Via A. Righi, 7 37135 Verona t. + 39 045 8088911</p>	<p><b>Centres in Crema:</b> Via Gaeta, 23   26013 Crema (CR) - I t. + 39 0373 890011</p>	<p><b>Centres in Montepandone:</b> Via Scopa, 20   63044 Montepandone (AP) - I t. + 39 0735 71051</p>
<p><b>Centres in Mozzecane:</b> Via Mediana   37060 Mozzecane (VR) - I t. + 39 045 6339400</p>	<p><b>Centres in Campoformido:</b> Via Principe di Udine, 118   33030 Campoformido (UD) - I t. + 39 0432 653611</p>	<p><b>Centres in Rivoli</b> Strada Settima, 5 10098 Rivoli (TO) Tel. +39 011 238 76 11</p>



The data and indications in this catalogue are purely for information and are provided without obligation and without any liability for Manni Sipre SpA.

This document is the property of Manni Sipre SpA; reproducing any images and texts contained therein without the written authorization of Manni Sipre SpA is prohibited.